



C E R T I F I C A T E

ATTESTATION CERTIFICATE OF MACHINERY AND LOW VOLTAGE DIRECTIVES

Technical file of the company mentioned below has been inspected and audit has been completed successfully. 2006/42/EC Machinery Directive and 2014/ 35/EU Low Voltage Directive have been taken as references for these processes

Company Name	:Topair Systems,INC.
Company Address	:8912 68th Avenue,Forest Hills,New York,11375,USA
Related Directives and Annex	:Low Voltage Directive 2014/35/EU Machinery Directive 2006/42/EC
Related Standards	:EN 60204-1:2006/AC:2010, EN ISO 12100:2010, EN ISO 13857:2008, EN ISO 14120:2015, EN 349:1993+A1:2008, EN ISO 13849-1:2015
Product Name	:Cyanoacrylate Fuming Chamber
Report No and Date	:TA-2017-04-07
Product Brand/Model/Typ	:SG-090-WF, SG-060, SG-070, SG-075, SG-080, SG-090, SG-100, SG-120, SG-150, SG-180, SG-260, SG-060-P, SG-070-P, SG-075-P, SG-080-P, SG-090-P, SG-100-P,SG-120-P, SG-150-P, SG-180-P, SG-260-P, SG-060-WF, SG-070-WF, SG-075-WF, SG-080-WF, SG-100-WF, SG-120-WF, SG-150-WF, SG-180-WF, SG-260-WF
Certificate Number	: M.2016.201.N1093
Initial Assessment Date	: 17.04.2017
Registration Date	: 19.04.2017
Reissue Date/No	: -
Expiry Date	: 18.04.2022

UDEM International Certification
Auditing Training Centre Industry
and Trade Co. Ltd.

The validity of the certificate can be checked through www.udemltd.com.tr. The CE mark shown on the right can only be used under the responsibility of the manufacturer with the completion of EC Declaration of Conformity for all the relevant Directives. This certificate remains the property of UDEM International Certification Auditing Training Centre Industry and Trade Co. Ltd. to whom it must be returned upon request. The above named firm must keep a copy of this certificate for 15 years from the registration of certificate. This certificate only covers the product(s) stated above and UDEM must be noticed in case of any changes on the product(s)



Address: Mutlukent Mahallesi 2073 Sokak (Eski 93 Sokak) No:10 Çankaya - Ankara - TURKEY

Phone: +90 0312 443 03 90 Fax: +90 0312 443 03 76

E-mail: info@udemltd.com.tr www.udemltd.com.tr

Technical Construction Files

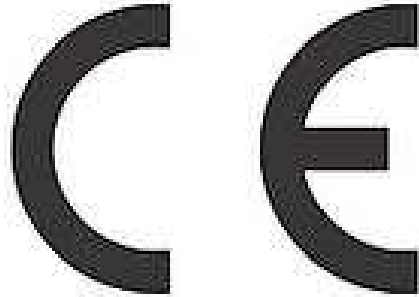

Cyanoacrylate Fuming Chamber



Model:

SG-090-WF, SG-060, SG-070, SG-075, SG-080, SG-090, SG-100, SG-120, SG-150, SG-180, SG-260, SG-060-P, SG-070-P, SG-075-P, SG-080-P, SG-090-P, SG-100-P, SG-120-P, SG-150-P, SG-180-P, SG-260-P, SG-060-WF, SG-070-WF, SG-075-WF, SG-080-WF, SG-100-WF, SG-120-WF, SG-150-WF, SG-180-WF, SG-260-WF

According to
2006/42/EC Machinery Directive
2014/35/EU Low Voltage Directive

TOPAIR SYSTEMS, INC.

8912 68th Avenue, Forest Hills, New York, 11375, USA

Technical File No.:	Issue Date:	Prepared by:	Approved by:
TA-2017-04-07	2017-04-19		

Documents Reference

No.	Content	Page
1.0	Information about The Manufacturer	3
2.0	EC Declaration of Conformity	4
3.0	Machine General Description	5
4.0	Quality Control System	6
5.0	Machine Pictures	10
6.0	Technical Specifications	11
7.0	Type/Model Designations	12
8.0	Machine Name Plate Sample	13
9.0	Part List	14
10.0	Machine Drawing	16
11.0	Circuit Drawing	17
12.0	Machine Instruction Manual	23
13.0	Hazards List	26
14.0	Essential Health and Safety Requirements (Annex I Machinery Directive 2006/42/EC)	28
15.0	List of The Applied Norms	28
16.0	Risk Evaluation Report According to EN ISO 12100:2010	39
17.0	General Test Report	40

1.0 Information about The Manufacturer

TOPAIR SYSTEMS, INC. is a collection product development design, production, sales and service in domestic and foreign research institutes, universities, health care, industrial and mining enterprises, quality supervision, environmental testing and other enterprises high-tech enterprises. The company mainly produces and sells various types of laboratory-related equipment, table cabinet and various professional colleges and universities laboratory equipment, Puke-based laboratory equipment. We have the spirit of "customer first, service first" business philosophy, with good business management and complete service system, is committed to environmental improvement project laboratories, GMP plant engineering, air purification engineering design, production, installation .

The company occupies a total area of over 5000 square meters, 50 workers redundant, of whom a college education of technical management staff of 40 people. The Italian company to introduce advanced production technology and equipment, as well as first-class technology and quality management personnel, while comprehensive import ISO9001, ISO14001 international quality management system, adhere to the superb technology, quality products, reasonable prices, better services to meet various research institutions, laboratories demand, the pursuit of technological progress of science and technology services.

2.0 EC Declaration of Conformity

EC Declaration of conformity

Council Directive
2006/42/EC Machinery Directive
2014/35/EU Low Voltage Directive

TOPAIR SYSTEMS, INC.

8912 68th Avenue, Forest Hills, New York, 11375, USA
TEL: + 1-855-686-7247 FAX: + 1-855-686-7247

Certify that the product described is in conformity with the Directive
2006/42/EC, 2014/35/EU as amended

Product Name:

Cyanoacrylate Fuming Chamber

Model:

SG-090-WF, SG-060, SG-070, SG-075, SG-080, SG-090, SG-100, SG-120, SG-150, SG-180, SG-260,
SG-060-P, SG-070-P, SG-075-P, SG-080-P, SG-090-P, SG-100-P, SG-120-P, SG-150-P, SG-180-P,
SG-260-P, SG-060-WF, SG-070-WF, SG-075-WF, SG-080-WF, SG-100-WF, SG-120-WF, SG-150-WF,
SG-180-WF, SG-260-WF

The product has been assessed by the application of the following standards:
EN 60204-1:2006/AC: 2010, EN ISO 12100:2010, EN ISO 13857:2008,
EN ISO 14120:2015, EN 349:1993+A1:2008, EN ISO 13849-1:2015

European representative:

NAME:

COMPANY NAME:

ADDRESS:

TEL:

Issue Place:
personnel:

Company stamp and Signature of authorized

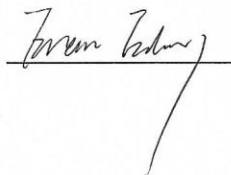

TOPAIR SYSTEMS, INC.

Date: 2017/04/18

3.0 Machine General Description

TopAir's Cyanoacrylate fuming chamber is used to develop latent prints from non-porous surfaces in a safe, controlled environment.

Basically, this kind of machine belongs to simple machine and with low risk when using it. All possible risk have been analyzed in the risk assessment report and been prevented by suitable ways.

The main risk of this kind of machine could be:

—The risk of access to the in-running nips.

—The risk of access to the power transmission elements.

—The risk of access to the area between moving parts and fixed parts which with crushing hazards.

In order to evaluate the main risks mentioned above, the occupational safety and health risk assessment has been done according to the requirement of EN ISO 12100:2010.

In order to ensure the conformity for CE marking for these machines, some main European and/or International standards have been used for the assessment of conformity, they are:

—EN 60204-1:2006/AC: 2010 Safety of machinery—Electrical equipment of machines—General requirements;

—EN ISO 12100:2010 Safety of machinery—General principles for design— Risk assessment and risk reduction;

—EN ISO 13857:2008 Safety of machinery—Safety distances to prevent hazard zones being reached by upper and lower limbs;

—EN ISO 14120:2015 Safety of machinery—Guards—General requirements for the design and construction of fixed and movable guards;

—EN 349:1993+A1:2008 Safety of machinery—Minimum gaps to avoid crushing of parts of the human body;

—EN ISO 13849-1:2015 Safety of machinery - Safety-related parts of control systems - Part 1: General principles for design (ISO 13849-1:2015).

The test reports for these applicable standards in detail have been included in the relevant sub-clauses of this technical construction file.

To present the conformity of this series machine with Machinery Directive and Low Voltage Directive, we discuss the conformity systematically with the relative Directive and standards.

4.0 Quality Control System

In order to ensure the conformity of the series production, our company has taken the related procedures mentioned below:

- 1) The complete technical construction file (TCF) has been established before applying for the CE marking certificate.
- 2) Carry out the inspection for parts and components according to the TCF
Before the assemblies of the series production, the QC engineers of our company have to check and inspect the technical specifications and intended functions of parts and components to ensure the correct use of them according to the contents of TCF and principle described in the related technical information.
- 3) Carry out the inspection & testing for the products before packing
Before packing the products, the QC engineers of our company have to do the necessary inspection and testing to ensure the conformity of related requirements.
- 4) Carry out the inspection for the packing
- 5) Provision for the change of design
- 6) Provision for the Quality Assurance

5.0 Machine Pictures

SG-090-WF









6.0 Technical Specifications

SG-090-WF

Spec/Model	SG-090-WF
Airflow (m ³ /hr)	250
Dimensions WxDxH	900 x 750 x 1550 mm 35.4 x 29.5 x 61"
Noise	<48 dBA
Lighting	LED 18 W
Main Filter (Qty.)	Water Trap
Temp & Humidity Accuracy	± 3%
Temperature	± 2°C

7.0 Type/Model Designations

Variations of The Series Products:

Regarding the whole family of the series, all models are with the same machine structure but with some small differences as following:

	/	P	WF
Type	SG-060, SG-070, SG-075, SG-080, SG-090, SG-100,SG-120, SG-150, SG-180, SG-260	SG-060-P, SG-070-P,SG-075-P, SG-080-P, SG-090-P, SG-100-P,SG-120-P, SG-150-P, SG-180-P, SG-260	SG-060-WF, SG-070-WF, SG-075-WF, SG-080-WF, SG-100-WF,SG-120-WF, SG-150-WF, SG-180-WF, SG-260-WF
Width: cm	60, 70, 75, 80, 90, 100, 120, 150, 180, 200		
Material	Aluminium alloy	Polypropylene plastics	Polypropylene plastics
Configuration	Vortex fan / activated carbon filter	Vortex fan / activated carbon filter	Air pump / water filter

8.0 Machine Name Plate Sample

Cyanoacrylate Fuming Chamber

SG-090-WF



Rated Power : 460W

Rated Voltage : 220V

Rated current: 2A

Date: 2017/04/05

Frequency : 50Hz

Serial No.:

TOPAIR SYSTEMS, INC.

8912 68th Avenue, Forest Hills, New York, 11375, USA

9.0 Part List

SG-090-WF

1	Control system
2	Temperature control
3	Main power
4	Electric lock
5	Automatic cycle
6	Humidity system
7	LED light
8	Electric system
9	Mix fan

10.0 Machine Drawing

SG-090-WF

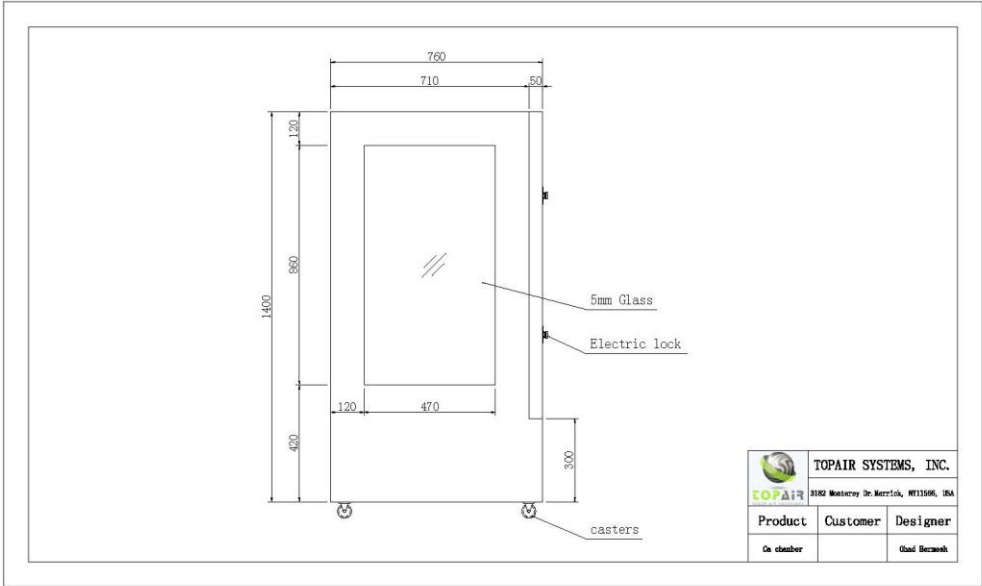
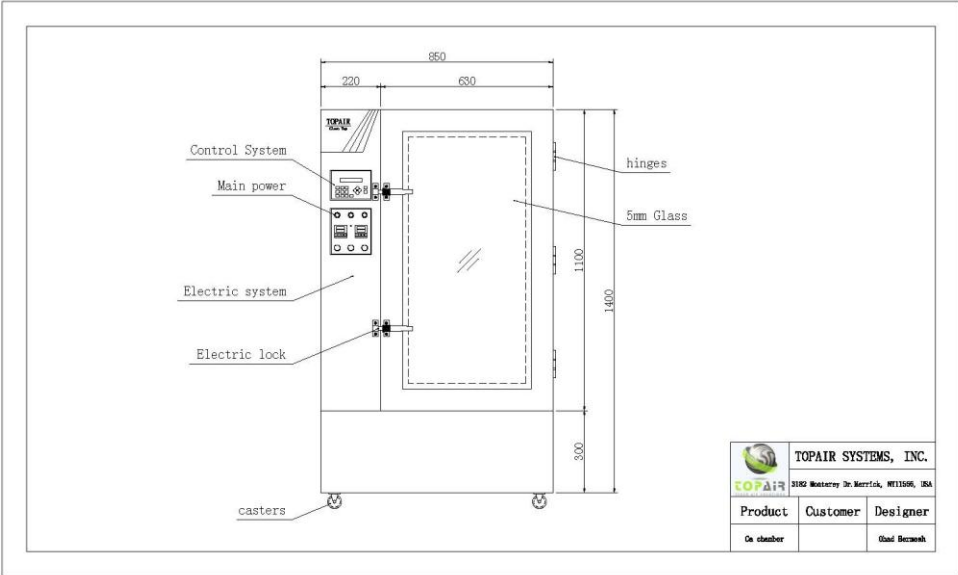

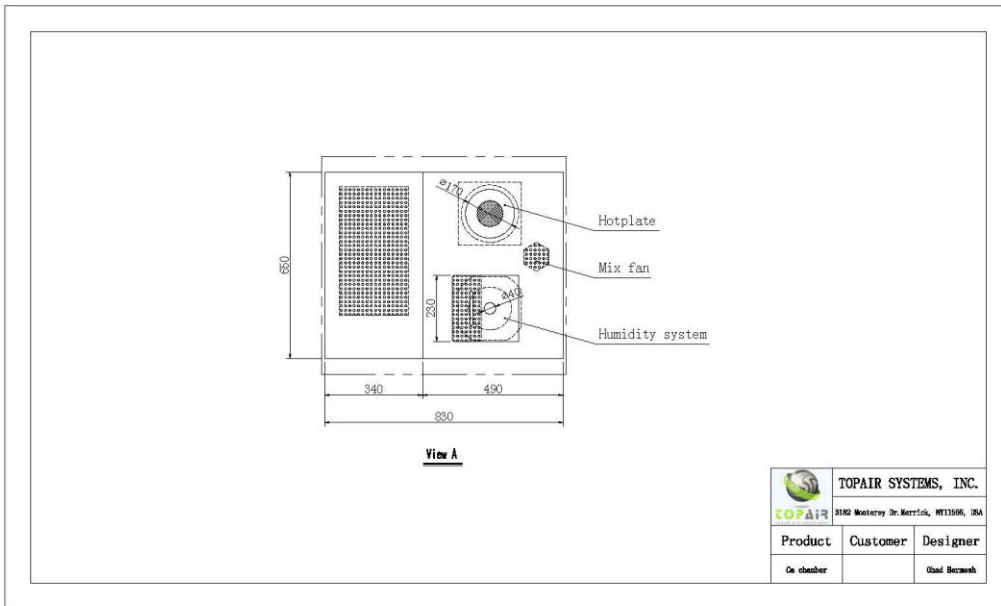
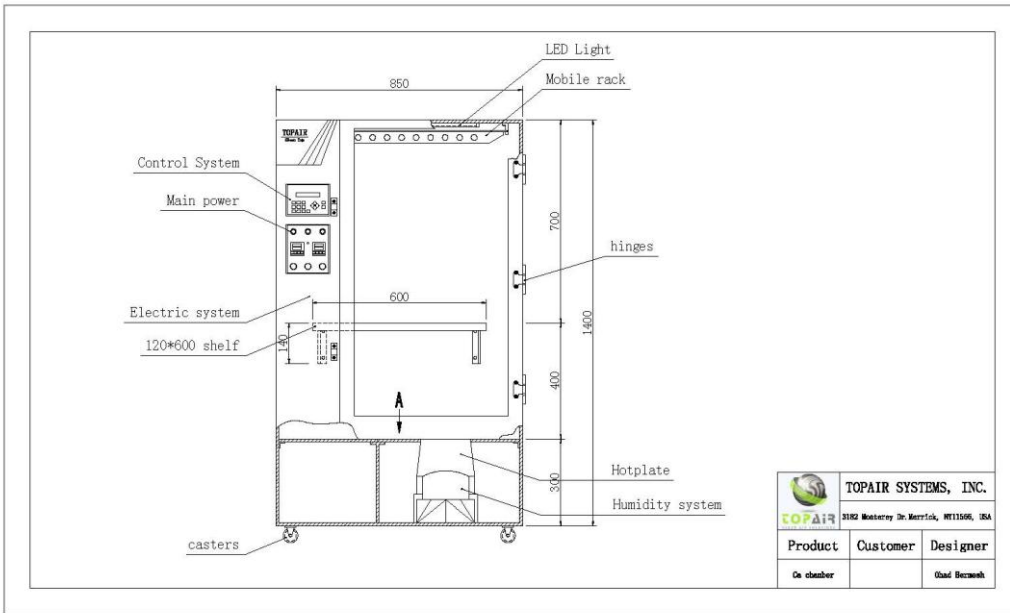

The file has been stored in the quality control system, and its number is TOPAIR-QR-D-SG-090-WF.

11.0 Machine Circuit Diagram

SG-090-WF

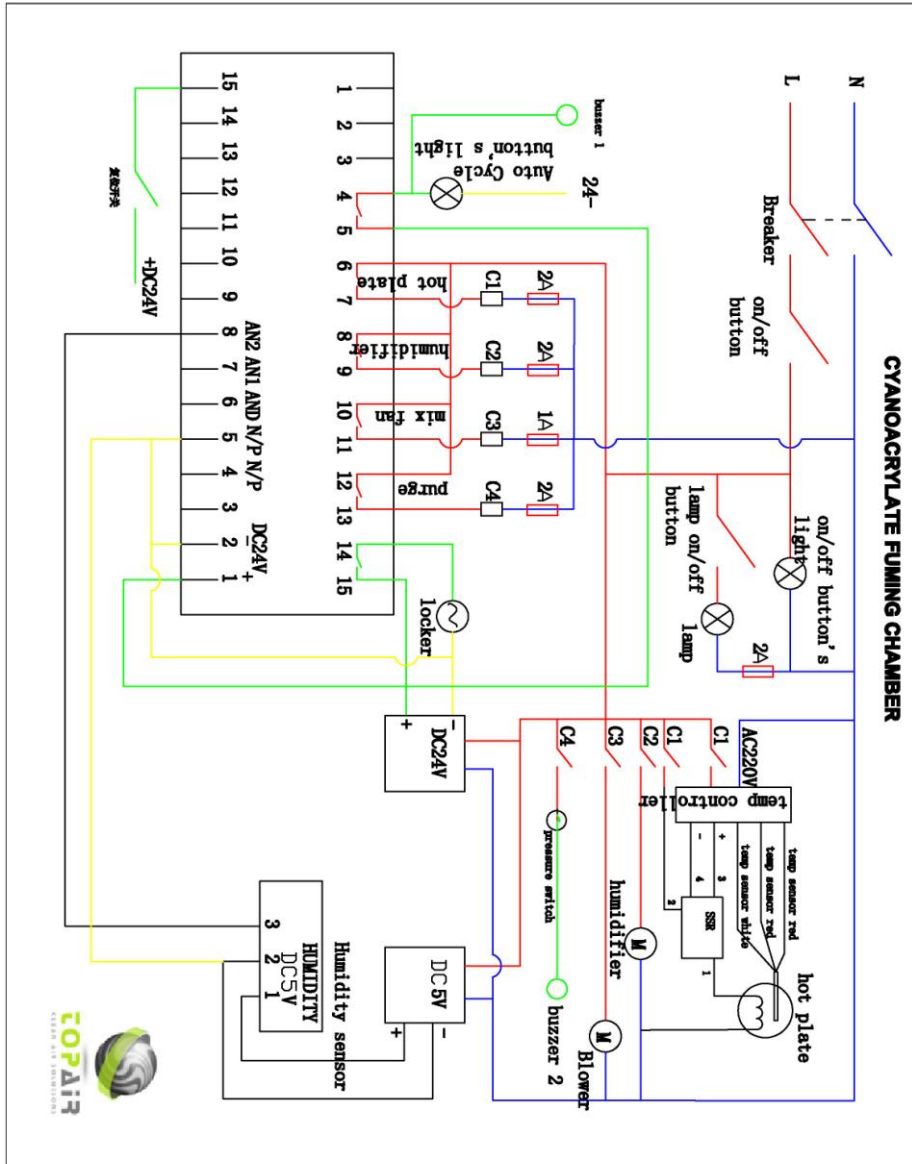

The file has been stored in the quality control system, and its number is TOPAIR-QR-C-SG-090-WF.

SG-090-WF

Cyanoacrylate Fuming Chamber

Operation Manual

Polypropylene Cyanoacrylate Fuming Chamber

TopAir's Cyanoacrylate Fuming Chamber is used to develop latent prints from non-porous surfaces in a safe, controlled environment.

Cyanoacrylate is placed inside the chamber while evidence is easily positioned using the adjustable hanging rods. Starting the cycle triggers the automated system to control the hotplate, humidity, door lock, internal circulation fan and purge cycle.

Its recirculatory design enables the system to operate and setup with no ducting required.

The cyanoacrylate vapors are filtered by a carbon filter. This ensures that no dangerous substances are exhausted in to the atmosphere surrounding the laboratory. Its ductless construction also allows the unit to be easily moved and transported.

- 3 sizes - from small benchtop units to larger walk-in chambers.
- Control System displaying all parameters of the processing cycle.
- Can be activated automatically, or manually with an option for temperature and humidity control.
- Filtering system with a carbon filter.
- Eco-friendly, cost-saving LED lighting.
- Alarm for end of automatic cycle
- Audio-Visual 30-second alarm.
- CE tested



Models

CUSTOM SIZES AVAILABLE!

Spec/Model	SG-060-P	SG-075-P	SG-090-P	SG-150-P
Airflow (m3/hr)	175	250	250	250
Dimensions WxDxH	600 x 600 x 760 mm 23.6 x 23.6 x 29.9"	750 x 740 x 1550 mm 29.5 x 29.5 x 61"	900 x 750 x 1550 mm 35.4 x 29.5 x 61"	1500 x 750 x 1550 mm 59 x 29.5 x 61"
Noise	<48 dBA	<48 dBA	<48 dBA	<48 dBA
Lighting	LED 18 W	LED 18 W	LED 18 W	LED 18 W
Main Filter (Qty.)	3 kg	5 kg	5 kg	8 kg
Prefilter (Qty.)	1	1	1	1
Power Supply	115 / 230V 50/60 Hz, Single phase			
Switches	Main ON/OFF			
Monitoring	Electronic Display			
Fan	Low Noise Centrifugal			
Construction	Polypropylene Structure, Safety Triplex Glass			
Production/Test Standard	CE			

Programmable Electronic Control

The electronic control system includes easy on-screen functions to program Purge Cycle, Contact Time and RH Sensor.



Filter Type	P/N
Main Filter	SG-CF
Pre Filter	SG-PF

Main and Pre Filters are supplied as standard with all chambers and are listed here for replacement purposes.

* Prefilters are supplied as standard with all units. Efficiencies are over 99.6%. The filters remove particles from the airstream before it flows through the Main Filter.

** Filters must be changed on a regular basis to maintain chamber efficiency.

Operation Process

- Evidence is placed within the chamber and cyanoacrylate is placed on the hotplate
- Door is closed and start button is pressed. Door locks automatically
- Evidence is placed within the chamber
- Humidifier is activated, increases humidity and releases vapors composed of 60%-80% humidity and fumes into the chamber
- Fuming continues for a half-hour cycle
- Once the cycle has completed, the evidence can be examined

Tel : +1-855-6-TOPAIR (+1-855-686-7247) Email: sales@topairsystems.com

Web: www.topairsystems.com | Headquarters USA: 8912 68th Avenue Forest Hills New York 11375, USA

Water Filtration Cyanoacrylate Fuming Chamber



NEW!

TopAir's Water Filtration Cyanoacrylate Fuming Chamber is used to develop latent prints from non-porous surfaces in a safe, controlled environment.

Cyanoacrylate is placed inside the chamber while evidence is easily positioned using the adjustable hanging rods. Starting the cycle triggers the automated system to control the hotplate, humidity, door lock, internal circulation fan, and purge cycle.

The Cyanoacrylate vapors are filtered using water filtration. This ensures that no dangerous substances are exhausted in to the atmosphere surrounding the laboratory.

The reaction of the fumes of cyanoacrylate to water causes the fumes turn into to non-hazardous plastic residue.

The filtration tank is equipped with a draining tap and a built-in washing/ refilling pipe. Removal of the filtration tank is not required for washing and refilling. The unit's recirculatory design enables the system to operate and setup with no ducting required. Its ductless construction also allows the unit to be easily moved and transported.

- Control system displaying all parameters of the processing cycle.
- Automatic heating control is determined according to the amount of cyanoacrylate placed in the chamber.
- Automatic temperature control Humidity control ensures $\pm 3\%$ humidity
- Water Filtration
- Eco-friendly, cost-saving LED lighting.
- CE tested

Models

CUSTOM SIZES AVAILABLE!

Spec/Model	SG-060-WF	SG-080-WF	SG-090-WF	SG-150-WF	SG-180-WF
Airflow (m3/hr)	175	250	250	250	250
Dimensions WxDxH	600 x 600 x 760 mm	800 x 740 x 1550 mm	900 x 750 x 1550 mm	1500 x 750 x 1550 mm	800 x 750 x 1400 mm
	23.6 x 23.6 x 29.9"	31.5 x 29.5 x 61"	35.4 x 29.5 x 61"	59 x 29.5 x 61"	31.5 x 29.5 x 55"
Noise	<48 dBA	<48 dBA	<48 dBA	<48 dBA	<48 dBA
Lighting	LED 18 W	LED 18 W	LED 18 W	LED 18 W	LED 18 W
Main Filter (Qty.)	Water Trap	Water Trap	Water Trap	Water Trap	Water Trap
Temp & Humidity Accuracy	± 3%	± 3%	± 3%	± 3%	± 3%
Temperature	± 2°C	± 2°C	± 2°C	± 2°C	± 2°C
Fan	High Pressure				--
Power Supply	115 / 230V 50/60 Hz, Single phase				
Switches	Main ON/OFF				
Monitoring	Electronic Display				
Construction	Polypropylene Structure, Safety Triplex Glass				
Production/Test Standard	CE				

Tel : +1-855-6-TOPAIR (+1-855-686-7247) Email: sales@topairsystems.com

Web: www.topairsystems.com | Headquarters USA: 8912 68th Avenue Forest Hills New York 11375, USA

Attention marks:



Safety mark "**Beware of electric shock**": Do not open the junction box of the motor until it is switched off to avoid electrical injury.



Important safety mark, prompting to avoid hand squeezing and head collision when the screen pressing mechanism is opened.



Operate according to the operating manual.



It is required to wear an auditory guard.



Safety mark "**Beware of injury from the machine**": Do not contact running parts with hands when the machine is running. The inspection, repair, disassembly or replacement etc. can be carried out only after the machine is stopped.



Do not remove the safety guard while the machine is running or before it has completely stopped.

13.0 Hazards List

Please check all row and Change Applicable/Not Applicable if is the case.

		Present	
		Yes	No
1	Mechanical hazards due to: 1) machine's parts or working pieces a) shape; b) related position; c) mass and balancing (potential energy of the element which can fall down under gravity effect); d) mass and speed (kinetic energy of the element which can move under controlled and uncontrolled movement); 2) energy accumulation into the machine due to: e) elastic element (springs); f) fluid and gas under pressure; g) vacuum effect;	X	
1.1	Crushing hazard	X	
1.2	Shearing hazard	X	
1.3	Cutting or severing hazard	X	
1.4	Entanglement hazard	X	
1.5	Drawing-in or trapping hazard	X	
1.6	Impact hazard	X	
1.7	Stabbing or puncture hazard	X	
1.8	Friction or abrasion hazard	X	
1.9	High pressure fluid or gas ejection hazard	X	
1.10	Parts ejection	X	
1.11	Lack of stability	X	
1.12	Slip, trip, fall related to the machine	X	
2	Electric hazard due to		
2.1	Direct and indirect electrical contact between people and live parts	X	
2.2	Electrostatic phenomena	X	
2.3	Thermal radiation or other phenomena such as projection of molten particles, and chemical effects from short circuits, overloads, etc.	X	
2.4	External influences	X	
3	Thermal hazards i.e. resulting in		
3.1	Burns and scalds, by a possible contact of persons, by flames or explosions and also by the radiator of heat source	X	
3.2	Health-damaging effects by hot or cold work environment	X	
4	Hazards generated by noise, resulting i.e. in:		
4.1	Hearing losses (deafness), other physiological disorder (i.e. loss of balance, loss of awareness, etc.)	X	
4.2	Interference with speech communication, acoustic signal, etc.	X	

5	Hazards generated by vibration (resulting in a variety of neurological and vascular disorders)		X	
6	Hazards generated by radiation			
6.1	Radiation at low frequency, radio frequency, microwaves, electric arcs		X	
6.2	Infrared-ray, light, UV-ray, lasers			X
6.3	X-ray, γ -ray			X
6.4	α -ray, β -ray, electron or ion beam, neutron beam			X
7	Hazards generated by materials and substances processed, used or exhausted by machinery i.e.			
7.1	Hazards resulting from contact with or inhalation of harmful fluids, gases, mists, fumes and dusts		X	
7.2	Fire or explosion hazards		X	
7.3	Biological and micro-biological (viral or bacterial) hazards		X	
8	Hazards generated by neglecting ergonomic principles in machine design (mismatch of machinery with human characteristics and abilities) caused i.e. by			
8.1	Unhealthy postures or excessive efforts.		X	
8.2	Inadequate consideration of human hand-arm or foot-leg anatomy		X	
8.3	Neglected use of PPE		X	
8.4	Inadequate area lighting		X	
8.5	Mental overload or underload, stress, etc.		X	
8.6	Human error		X	
9	Hazards combination		X	
10	Hazards caused by failure of energy supply, breaking down of machinery parts and other functional disorders, i.e.			
10.1	Failure, malfunction of control system (unexpected start up, unexpected overrun)		X	
10.2	Unexpected ejection of machine parts or fluids.		X	
10.3	Control malfunctioning		X	
10.4	Error of fitting		X	
10.5	Overturn, unexpected loss of machine stability		X	
11	Hazardous due to means/devices related to the safety missing or in wrong position			
11.1	Missing guards		X	
11.2	Missing safety devices		X	
11.3	Starting and stopping devices		X	
11.4	Safety sign		X	
11.5	Information and warning means		X	
11.6	Energy disconnecting devices		X	
11.7	Emergency devices		X	
11.8	Working piece feeding		X	
11.9	Maintenance equipment		X	
11.10	Gas evacuation		X	
	Hazards due to mobility			
12	Inadequate lighting		X	

13	Instability		X	
14	Neglected ergonomic of the control position			
14.1	Hazards due to dangerous environment (contact with moving parts, exhaust, etc.)		X	
14.2	Inadequate visibility by the operators		X	
14.3	Inadequate seating		X	
14.4	Inadequate controls		X	
14.5	Starting in machine with engine		X	
14.6	Road traffic		X	
14.7	Pedestrian control		X	
15	Mechanical hazards			
15.1	Uncontrolled movement		X	
15.2	Parts ejection		X	
15.3	Roll over		X	
15.4	Falling objects		X	
15.5	Inadequate access		X	
15.6	Towing		X	
15.7	Batteries			X
16	Hazards due to lifting operation			
16.1	Lack of stability		X	
16.2	Derailment		X	
16.3	Loss of mechanical strength of the machine		X	
16.4	Uncontrolled movement		X	
16.5	Falling loads		X	
17	Inadequate view		X	
18	Lighting		X	
19	Overloading		X	

14.0 Essential Health and Safety Requirements (Annex I Machinery Directive 2006/42/EC)

Please check all row and Change Applicable/NApplicable if is the case.

Ref.	E.H.S.R.	A	NA	Meet the requirement?
1.1	General remarks	X		Y
1.1.1	Definition	X		Y
1.1.2	Principles of safety integration	X		Y
1.1.3	Materials and products	X		Y
1.1.4	Lighting	X		Y
1.1.5	Design of machinery to facilitate its handling	X		Y
1.2	Controls			
1.2.1	Safety and reliability of control systems	X		Y
1.2.2	Control devices	X		Y
1.2.3	Starting	X		Y
1.2.4	Stopping device (normal stopping, emergency stop)	X		Y
1.2.5	Mode selection	X		Y



1.2.6	Failure of the power supply	X		Y
1.2.7	Failure of the control circuit	X		Y
1.2.8	Software	X		
1.3	Protection against mechanical hazards			
1.3.1	Stability	X		Y
1.3.2	Risk of break-up during operation	X		Y
1.3.3	Risks due to falling or ejected objects	X		
1.3.4	Risks due to surfaces, edges or angles	X		Y
1.3.5	Risks related to combined machinery	X		Y
1.3.6	Risks relating to variations in the rotational speed of tools	X		Y
1.3.7	Prevention of risks related to moving parts	X		Y
1.3.8	Choice of protection against risks related to moving parts (transmission parts, moving parts directly involved in the process, etc.)	X		Y
1.4	Required characteristics of guards and protection devices	X		Y
1.4.1	General requirements	X		Y
1.4.2	Special requirements for guards	X		Y
1.4.2.1	Fixed guards	X		Y
1.4.2.2	Movable guards	X		Y
1.4.2.3	Adjustable guards restricting access	X		Y
1.4.3	Special requirements for protection devices	X		Y
1.5	Protection against other hazards	X		Y
1.5.1	Electricity supply	X		Y
1.5.2	Static electricity	X		Y
1.5.3	Energy supply other than electricity	X		Y
1.5.4	Errors of fitting	X		Y
1.5.5	Extreme temperatures	X		Y
1.5.6	Fire		X	Y
1.5.7	Explosion		X	Y
1.5.8	Noise	X		Y
1.5.9	Vibration	X		Y
1.5.10	Radiation		X	
1.5.11	External radiation		X	
1.5.12	Laser equipment		X	
1.5.13	Emissions of dust, gases, etc.		X	Y
1.5.14	Risk of being trapped in a machine	X		Y
1.5.15	Risk of slipping, tripping or falling	X		Y
1.6	Maintenance			
1.6.1	Machinery maintenance	X		Y
1.6.2	Access to operating position and servicing points	X		Y
1.6.3	Isolation of energy sources	X		Y
1.6.4	Operator intervention	X		Y
1.6.5	Cleaning of internal parts	X		Y
1.7	Indicators	X		Y
1.7.0	Information devices	X		Y

1.7.1	Warning devices	X		Y
1.7.2	Warning of residual risks	X		Y
1.7.3	Marking	X		Y
1.7.4	Instructions	X		Y

A = Applicable; NA = Not Applicable

15.0 List of The Applied Norms

Norms number	Description
EN 60204-1:2006/AC:2010	Safety of machinery—Electrical equipment of machines—General requirements
EN ISO 12100:2010	Safety of machinery—General principles for design—Risk assessment and risk reduction
EN ISO 13857:2008	Safety of machinery—Safety distances to prevent hazard zones being reached by upper and lower limbs
EN ISO 14120:2015	Safety of machinery—Guards—General requirements for the design and construction of fixed and movable guards
EN 349:1993+A1:2008	Safety of machinery—Minimum gaps to avoid crushing of parts of the human body
EN ISO 13849-1:2015	Safety of machinery - Safety-related parts of control systems - Part 1: General principles for design (ISO 13849-1:2015)

Technical File No.:	Issue Date:	Prepared by:	Approved by:
TA-2017-04-07	2017-04-19		

16.0 Risk Evaluation Report According to EN ISO 12100:2010

Evaluation Procedure

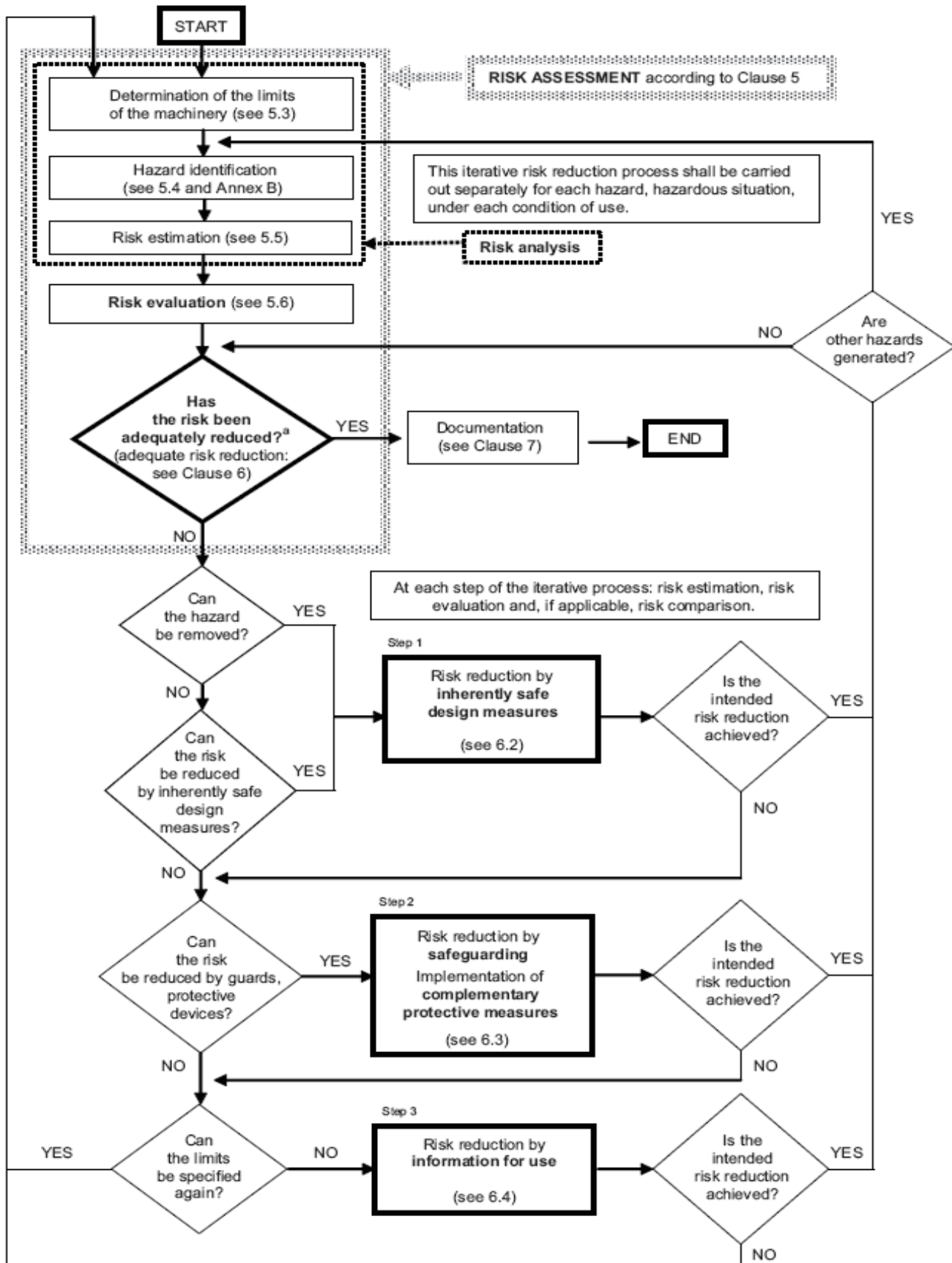

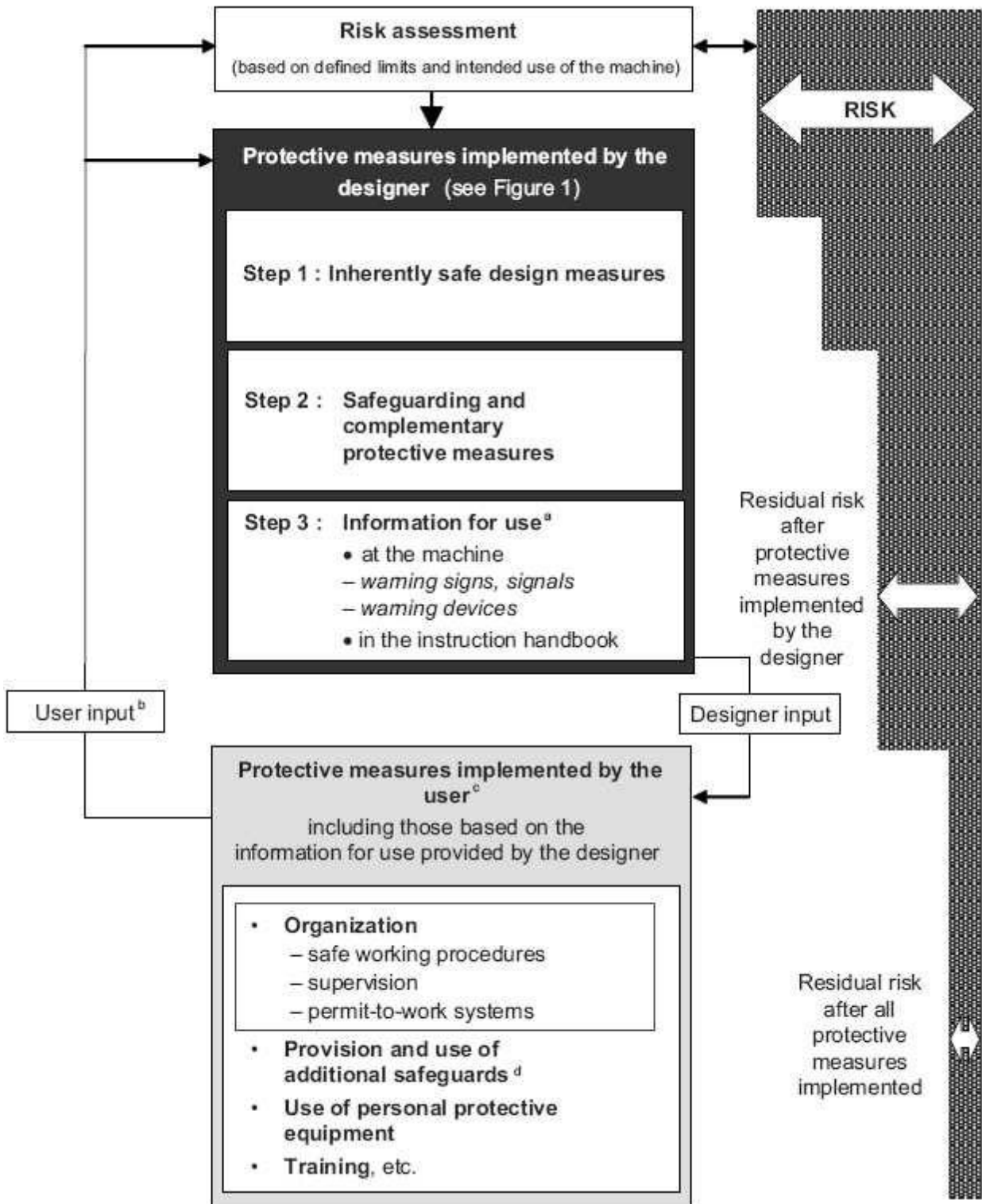

Determination of limits for machinery		
Use limits	the different machine operating modes and different intervention procedures for the users, including interventions required by malfunctions of the machine:	
	the use of the machinery (for example, industrial, non-industrial and domestic) by persons identified by sex, age, dominant hand usage, or limiting physical abilities (visual or hearing impairment, size, strength, etc.);	Industrial use only
	the anticipated levels of training, experience or ability of users including 1) operators, 2) maintenance personnel or technicians, 3) trainees and apprentices, and 4) the general public;	Licensed operator only Don't overload.
	exposure of other persons to the hazards associated with the machinery where it can be reasonably foreseen: 1 persons likely to have a good awareness of the specific hazards, such as operators of adjacent machinery; 2 persons with little awareness of the specific hazards but likely to have a good awareness of site safety procedures, authorized routes, etc, such as administration staff; 3 persons likely to have very little awareness of the machine hazards or the site safety procedures, such as visitors or members of the general public, including children.	The operator has to been trained and has to been aware of the potential risk of operating the machine. The operator should have due PPE when operate the machine. The operator has to following the instruction when operate the machine. The operator has to pay attention to people who is around the machine when operate the machine.
Space limits	Aspects of space limits to be taken into account include 4 the range of movement, 5 space requirements for persons interacting with the machine, such as during operation and maintenance, 6 human interaction such as the operator–machine interface, and 7 the machine–power supply interface.	

Time limits	Aspects of time limits to be taken into account include 8 the life limit of the machinery and/or of some of its components (tooling, parts that can wear, electromechanical components, etc.), taking into account its intended use and reasonably foreseeable misuse, and 9 recommended service intervals.		None		
Other limits	Examples of other limits include 10 properties of the material(s) to be processed, 11 housekeeping — the level of cleanliness required, and 12 environmental — the recommended minimum and maximum temperatures, whether the machine can be operated indoors or outdoors, in dry or wet weather, in direct sunlight, tolerance to dust and wet, etc.				
Risk Level			P³=3	P³=2	P³=1
E ¹ =1			1	---	---
E ¹ =2	E ² =1	A ⁴ =1	2	1	---
		A ⁴ =2	3	2	1
		A ⁴ =3	4	3	2
	E ² =2	A ⁴ =1	5	4	3
		A ⁴ =2	6	5	4
		A ⁴ =3	7	6	5
	E ² =3	A ⁴ =1	8	7	6
		A ⁴ =2	9	8	7
		A ⁴ =3	10	9	8
E ¹ =3	E ² =1	A ⁴ =1	11	10	9
		A ⁴ =2	12	11	10
		A ⁴ =3	13	12	11
	E ² =2	A ⁴ =1	14	13	12

	E2=3	A4=2	15	14	13
		A4=3	16	15	14
		A4=1	17	16	15
		A4=2	18	17	16
		A4=3	19	18	17
E1=4			20	19	18
Parameters: E1, Effect (degree of possible harm). 1 Minor, 2 Moderate, 3 Severe, 4 Death or Catastrophic E2, Exposure to danger 1 Seldom, 2 Frequent, 3 Continuous			P3, Probability of occurrence of harm 1 Low, 2 Medium, 3 High A4, possibility of Avoiding or limiting harm 1 Easily, 2 Possible, 3 Impossible If risk level > 9, Means a special safety measured scheme is required		

	Type of Hazards	Life of Cycle	Identified hazards		ISO 12100	Risk evaluation					Safety Measured scheme	Protective Measure	Adequate ?
			Origin ^a	Potential consequences ^b		E ¹	E ²	P ³	A ⁴	Risk Level			
1	Mechanical hazards	<input type="checkbox"/> transport <input checked="" type="checkbox"/> assembly and installation <input type="checkbox"/> commissioning <input checked="" type="checkbox"/> use <input type="checkbox"/> dismantling, disabling and scrapping.	<input type="checkbox"/> acceleration, deceleration; <input type="checkbox"/> angular parts; <input type="checkbox"/> approach of a moving element to a fixed part; <input type="checkbox"/> cutting parts; <input type="checkbox"/> elastic elements; <input type="checkbox"/> falling objects; <input type="checkbox"/> gravity; <input type="checkbox"/> height from the	<input checked="" type="checkbox"/> being run over; <input type="checkbox"/> being thrown; <input type="checkbox"/> crushing; <input type="checkbox"/> cutting or severing; <input checked="" type="checkbox"/> drawing-in or trapping; <input type="checkbox"/> entanglement; <input type="checkbox"/> friction or abrasion; <input type="checkbox"/> impact;	6.2.2.1 6.2.2.2 6.2.3 a) 6.2.3 b) 6.2.6 6.2.10 6.3.1 6.3.2 6.3.3 6.3.5.2 6.3.5.4	3	1	1	2	10	Required	Set up obvious warning sign. Machines designed according to EN 349:1993+A1:2008, EN ISO 14120:2015 and EN ISO 13857:2008. Operation under instruction Due PPE been used	Adequate

			<ul style="list-style-type: none"> ground; <input checked="" type="checkbox"/> high pressure; <input checked="" type="checkbox"/> instability; <input type="checkbox"/> kinetic energy; <input type="checkbox"/> machinery mobility; <input type="checkbox"/> moving elements; <input type="checkbox"/> rotating elements; <input type="checkbox"/> rough, slippery surface; <input type="checkbox"/> sharp edges; <input type="checkbox"/> stored energy; <input type="checkbox"/> vacuum. 	<ul style="list-style-type: none"> <input type="checkbox"/> injection; <input type="checkbox"/> shearing; <input type="checkbox"/> slipping, tripping and falling; <input type="checkbox"/> stabbing or puncture; <input type="checkbox"/> Suffocation. 	6.3.5.5										
2	Electrical hazards	<ul style="list-style-type: none"> <input type="checkbox"/> transport <input type="checkbox"/> assembly and installation <input type="checkbox"/> commissioning <input checked="" type="checkbox"/> use <input type="checkbox"/> dismantling, disabling and scrapping. 	<ul style="list-style-type: none"> <input type="checkbox"/> arc; <input type="checkbox"/> electromagnetic phenomena; <input type="checkbox"/> electrostatic phenomena; <input checked="" type="checkbox"/> live parts; <input checked="" type="checkbox"/> not enough distance to live parts under high voltage; <input type="checkbox"/> overload; <input type="checkbox"/> parts which have 	<ul style="list-style-type: none"> <input type="checkbox"/> burn; <input type="checkbox"/> chemical effects; <input type="checkbox"/> effects on medical implants; <input type="checkbox"/> electrocution; <input checked="" type="checkbox"/> falling, being thrown; <input type="checkbox"/> fire; <input type="checkbox"/> projection of molten particles; <input checked="" type="checkbox"/> shock. 	6.2.9	3	1	1	2	10	Required	<p>Machines designed according to EN 60204-1</p> <p>Due PPE been used</p> <p>Operation under instruction</p>	Adequate		

			become live under fault conditions; <input checked="" type="checkbox"/> short-circuit; <input type="checkbox"/> thermal radiation.										
3	Thermal hazards	<input type="checkbox"/> transport <input type="checkbox"/> assembly and installation <input type="checkbox"/> commissioning <input checked="" type="checkbox"/> use <input type="checkbox"/> dismantling, disabling and scrapping.	<input type="checkbox"/> explosion; <input type="checkbox"/> flame; <input type="checkbox"/> objects or materials with a high <input type="checkbox"/> or low temperature; <input type="checkbox"/> radiation from heat sources.	<input type="checkbox"/> burn; <input type="checkbox"/> dehydration; <input type="checkbox"/> discomfort; <input type="checkbox"/> frostbite; <input type="checkbox"/> injuries by the radiation of heat sources; <input checked="" type="checkbox"/> scald.	6.2.4 b) 6.2.8 c) 6.3.2.7 6.3.3.2.1 6.3.4.5	2	2	3	1	5	Not required	Operation under instruction	
4	Noise hazards	<input type="checkbox"/> transport <input type="checkbox"/> assembly and installation <input type="checkbox"/> commissioning <input checked="" type="checkbox"/> use <input type="checkbox"/> dismantling, disabling and scrapping.	<input type="checkbox"/> cavitation phenomena; <input checked="" type="checkbox"/> exhausting system; <input type="checkbox"/> gas leaking at high speed; <input type="checkbox"/> manufacturing process (stamping, cutting, etc.); <input type="checkbox"/> moving parts; <input type="checkbox"/> scraping surfaces; <input type="checkbox"/> unbalanced rotating parts; <input type="checkbox"/> whistling pneumatics;	<input checked="" type="checkbox"/> discomfort; <input type="checkbox"/> loss of awareness; <input type="checkbox"/> loss of balance; <input checked="" type="checkbox"/> permanent hearing loss; <input type="checkbox"/> stress; <input type="checkbox"/> tinnitus; <input type="checkbox"/> tiredness; <input type="checkbox"/> any other (for example, mechanical, electrical) as a consequence of	6.2.2.2 6.2.3 c) 6.2.4 c) 6.2.8 c) 6.3.1 6.3.2.1 b) 6.3.2.5.1 6.3.3.2.1 6.3.4.2 6.4.3 6.4.5.1 b) and c)	2	2	2	2	5	Not required	Due PPE been used	

			<input type="checkbox"/> worn parts.	an interference with speech communication or with acoustic signals.									
5	Vibration hazards	<input type="checkbox"/> transport <input type="checkbox"/> assembly and installation <input type="checkbox"/> commissioning <input type="checkbox"/> use <input type="checkbox"/> dismantling, disabling and scrapping.	<input type="checkbox"/> cavitation phenomena; <input type="checkbox"/> misalignment of moving parts; <input type="checkbox"/> mobile equipment; <input type="checkbox"/> scraping surfaces; <input type="checkbox"/> unbalanced rotating parts; <input type="checkbox"/> vibrating equipment; <input type="checkbox"/> worn parts.	<input type="checkbox"/> discomfort; <input type="checkbox"/> low-back morbidity; <input type="checkbox"/> neurological disorder; <input type="checkbox"/> osteo-articular disorder; <input type="checkbox"/> trauma of the spine; <input type="checkbox"/> vascular disorder.	6.2.2.2 6.2.3 c) 6.2.8 c) 6.3.3.2.1 6.3.4.3 6.4.5.1 c)	2	2	2	2	5	Not required		
6	Radiation hazards	<input type="checkbox"/> transport <input type="checkbox"/> assembly and installation <input type="checkbox"/> commissioning <input type="checkbox"/> use <input type="checkbox"/> dismantling, disabling and scrapping.	<input type="checkbox"/> ionizing radiation source; <input type="checkbox"/> low frequency electromagnetic radiation; <input type="checkbox"/> optical radiation (infrared, visible and ultraviolet), including laser; <input type="checkbox"/> radio frequency	<input type="checkbox"/> burn; <input type="checkbox"/> damage to eyes and skin; <input type="checkbox"/> effects on reproductive capability; <input type="checkbox"/> mutation; <input type="checkbox"/> headache, insomnia, etc.	6.2.2.2 6.2.3 c) 6.3.3.2.1 6.3.4.5 6.4.5.1 c)	2	1	1	1	---	Not required		

			Electromagnetic radiation.											
7	Material/ substance hazards	<input type="checkbox"/> transport <input type="checkbox"/> assembly and installation <input type="checkbox"/> commissioning <input checked="" type="checkbox"/> use <input type="checkbox"/> dismantling, disabling and scrapping.	<input type="checkbox"/> aerosol; <input type="checkbox"/> biological and microbiological (viral or bacterial) agent; <input type="checkbox"/> combustible; <input checked="" type="checkbox"/> dust; <input type="checkbox"/> explosive; <input type="checkbox"/> fibre; <input type="checkbox"/> flammable; <input checked="" type="checkbox"/> fluid; <input type="checkbox"/> fume; <input checked="" type="checkbox"/> gas; <input type="checkbox"/> mist; <input type="checkbox"/> oxidizer.	<input checked="" type="checkbox"/> breathing difficulties, suffocation; <input checked="" type="checkbox"/> cancer; <input type="checkbox"/> corrosion; <input type="checkbox"/> effects on reproductive capability; <input type="checkbox"/> explosion; <input type="checkbox"/> fire; <input type="checkbox"/> infection; <input type="checkbox"/> mutation; <input type="checkbox"/> poisoning; <input type="checkbox"/> sensitization.	6.2.2.2 6.2.3 b) 6.2.3 c) 6.2.4 a) 6.2.4 b) 6.3.1 6.3.3.2.1 6.3.4.4 6.4.5.1 c) 6.4.5.1 g)	3	3	2	2	14	Required	Due PPE been used		
8	Ergonomic hazards	<input type="checkbox"/> transport <input type="checkbox"/> assembly and installation <input type="checkbox"/> commissioning <input type="checkbox"/> use <input type="checkbox"/> dismantling, disabling and scrapping.	<input type="checkbox"/> access; <input type="checkbox"/> design or location of indicators and visual displays units; <input type="checkbox"/> design, location or identification of control devices; <input type="checkbox"/> effort;	<input type="checkbox"/> discomfort; <input type="checkbox"/> fatigue; <input type="checkbox"/> musculoskeletal disorder; <input type="checkbox"/> stress; <input type="checkbox"/> any other (for example, mechanical, electrical) as a	6.2.2.1 6.2.7 6.2.8 6.2.11.8 6.3.2.1 6.3.3.2.1	2	2	2	3	1	Not required			



			<input type="checkbox"/> flicker, dazzling, shadow, stroboscopic effect; <input type="checkbox"/> local lighting; <input type="checkbox"/> mental overload/under load; <input type="checkbox"/> posture; <input type="checkbox"/> repetitive activity; <input type="checkbox"/> visibility.	consequence of a human error.									
9	Hazards associated with the environment in which the machine is used	<input type="checkbox"/> transport <input type="checkbox"/> assembly and installation <input type="checkbox"/> commissioning <input checked="" type="checkbox"/> use <input type="checkbox"/> dismantling, disabling and scrapping.	<input type="checkbox"/> dust and fog; <input type="checkbox"/> electromagnetic disturbance; <input type="checkbox"/> lightning; <input type="checkbox"/> moisture; <input type="checkbox"/> pollution; <input checked="" type="checkbox"/> snow; <input type="checkbox"/> temperature; <input checked="" type="checkbox"/> water; <input type="checkbox"/> wind; <input type="checkbox"/> lack of oxygen.	<input type="checkbox"/> burn; <input type="checkbox"/> slight disease; <input checked="" type="checkbox"/> slipping, falling; <input type="checkbox"/> suffocation; <input type="checkbox"/> any other as a consequence of the effect caused by the sources of the hazards on the machine or parts of the machine.	6.2.6 6.2.11.11 6.3.2.1 6.4.5.1 b)	2	2	2	3	1	Not required		
10	Combination of hazards	<input type="checkbox"/> transport <input type="checkbox"/> assembly and installation <input type="checkbox"/> commissioning	<input type="checkbox"/> for example, repetitive activity +effort + high environmental	<input type="checkbox"/> for example, dehydration, loss of awareness, heat stroke	—	2	2	2	3	1	Not required		

	<input type="checkbox"/> use <input type="checkbox"/> dismantling, disabling and scrapping.	temperature												
--	--	-------------	--	--	--	--	--	--	--	--	--	--	--	--

a A single origin of a hazard can have several potential consequences.

b For each type of hazard or group of hazards, some potential consequences can be related to several origins of hazard.

Conclusions: From risk evaluation results that if the machine is used under normal safety condition and following what is written in the use and maintenance manual, there are not situation with strong risk. For each dangerous situation some warning and precaution are listed in the manual, which allow the operators to work with low risk, also in the manual there is a list of safety advices to reduce the risks.

Technical File No.:	Issue Date:	Prepared by:	Approved by:
TA-2017-04-07	2017-04-19		

17.0 General Test Report



INFORMATION	
Applicant Name:	TOPAIR SYSTEMS, INC.
Address:	8912 68th Avenue, Forest Hills, New York, 11375, USA
Manufacturer Name:	TOPAIR SYSTEMS, INC.
Address:	8912 68th Avenue, Forest Hills, New York, 11375, USA

PROJECT INFORMATION	
Product name:	Cyanoacrylate Fuming Chamber
Model(s)	SG-090-WF, SG-060, SG-070, SG-075, SG-080, SG-090, SG-100, SG-120, SG-150, SG-180, SG-260, SG-060-P, SG-070-P, SG-075-P, SG-080-P, SG-090-P, SG-100-P, SG-120-P, SG-150-P, SG-180-P, SG-260-P, SG-060-WF, SG-070-WF, SG-075-WF, SG-080-WF, SG-100-WF, SG-120-WF, SG-150-WF, SG-180-WF, SG-260-WF
Standard/Edition	EN 60204-1:2006/AC: 2010, EN ISO 12100:2010, EN ISO 13857:2008, EN ISO 14120:2015, EN 349:1993+A1:2008, EN ISO 13849-1:2015
Requested Service	<input checked="" type="checkbox"/> Full or partial pre-test for the following certification <input type="checkbox"/> CE- MD <input type="checkbox"/> CE- LVD <input type="checkbox"/> CE- EMC <input type="checkbox"/> Others

SAMPLE RECORDS		
Sample	Quantity	Description
SG-090-WF	1	Complete, Well for testing
Conclusion: The sample(s) were tested according to the standard(s) specified above and found COMPLIANCE with the applicable requirements. April 19 th , 2017		

Testing Introduction

Test item particulars: Equipment mobility.....movable 1 Practical tests for Type Testing Procedure 2 Practical tests for fitness for purpose test when SG-090-WF has been type tested
Test case verdicts Test case does not apply to the test object.....: N(A.) Test item does meet the requirement.....: P(Pass) Test item does not meet the requirement.....: F(Fail)
General remarks The test results presented in this report relate only to the object tested. This report shall not be reproduced except in full without the written approval of the testing laboratory. The test results presented in this report relate only to the item(s) tested, "(see remark #)" refers to a remark appended to the report, "(see Annex #)" refers to an annex appended to the report. Throughout this report a comma is used as the decimal separator.

Technical File No.:	Issue Date:	Prepared by:	Approved by:
TA-2017-04-07	2017-04-19		

Clause	Requirement-Test	Result	Verdict
--------	------------------	--------	---------

EN ISO 12100

6	Risk reduction		
	<p>The objective of risk reduction can be achieved by the elimination of hazards, or by separately or simultaneously reducing each of the two elements that determine the associated risk:</p> <ul style="list-style-type: none"> —severity of harm from the hazard under consideration; —probability of occurrence of that harm. <p>All protective measures intended for reaching this objective shall be applied in the following sequence, referred to as the three-step method (see also Figures 1 and 2).</p> <p>Step 1: Inherently safe design measures</p> <p>Step 2: Safeguarding and/or complementary protective measures</p> <p>Step 3: Information for use</p>	P	

6.2 Inherently safe design measures

6.2.1	General		
	<p>Inherently safe design measures are the first and most important step in the risk reduction process. This is because protective measures inherent to the characteristics of the machine are likely to remain effective, whereas experience has shown that even well-designed safeguarding can fail or be violated and information for use may not be followed.</p> <p>Inherently safe design measures are achieved by avoiding hazards or reducing risks by a suitable choice of design features for the machine itself and/or interaction between the exposed persons and the machine.</p>	P	

6.2.2 Consideration of geometrical factors and physical aspects

6.2.2.1	Geometrical factors		
	<p>Such factors include the following.</p> <p>a) The form of machinery is designed to maximize direct visibility of the working areas and hazard zones from the control position — reducing blind spots, for example — and choosing and locating means of indirect vision where necessary (mirrors, etc.) so as to take into account the characteristics of human vision, particularly when safe operation requires permanent direct control by the operator, for example:</p> <ul style="list-style-type: none"> —the travelling and working area of mobile machines; —the zone of movement of lifted loads or of the carrier of machinery for lifting persons; —the area of contact of the tool of a hand-held or hand-guided machine with the material being worked. <p>The design of the machine shall be such that, from the main control position, the operator is able to ensure that there are no exposed persons in the danger zones.</p> <p>b) The form and the relative location of the mechanical components parts: for instance, crushing and shearing hazards are avoided by increasing the minimum gap between the moving parts, such that the part of the body under consideration can enter the gap safely, or by reducing the gap so that no part of the body can enter it (see ISO 13854 and ISO 13857).</p> <p>c) Avoiding sharp edges and corners, protruding parts: in so far as their purpose allows, accessible parts of the machinery shall have no sharp edges, no sharp angles, no rough surfaces, no protruding parts likely to cause injury, and no openings which can “trap” parts of the body or clothing. In particular, sheet metal edges shall be deburred, flanged or trimmed, and open ends of tubes which can cause a “trap” shall be capped.</p> <p>d) The form of the machine is designed so as to achieve a suitable working position and provide</p>	P	

Clause	Requirement-Test	Result	Verdict
--------	------------------	--------	---------

	accessible manual controls (actuators).		
6.2.2.2	Physical aspects		
	<p>Such aspects include the following:</p> <ul style="list-style-type: none"> a) limiting the actuating force to a sufficiently low value so that the actuated part does not generate a mechanical hazard; b) limiting the mass and/or velocity of the movable elements, and hence their kinetic energy; c) limiting the emissions by acting on the characteristics of the source using measures for reducing <ul style="list-style-type: none"> 1) noise emission at source (see ISO/TR 11688-1), 2) the emission of vibration at source, such as redistribution or addition of mass and changes of process parameters [for example, frequency and/or amplitude of movements (for hand-held and hand-guided machinery, see CR 1030-1)], 3) the emission of hazardous substances, including the use of less hazardous substances or dust-reducing processes (granules instead of powders, milling instead of grinding), and 4) radiation emissions, including, for example, avoiding the use of hazardous radiation sources, limiting the power of radiation to the lowest level sufficient for the proper functioning of the machine, designing the source so that the beam is concentrated on the target, increasing the distance between the source and the operator or providing for remote operation of the machinery [measures for reducing emission of non-ionizing radiation are given in 6.3.4.5 (see also EN 12198-1 and EN 12198-3)]. 	P	
6.2.3	Taking into account general technical knowledge of machine design		
	<p>This general technical knowledge can be derived from technical specifications for design (standards, design codes, calculation rules, etc.), which should be used to cover</p> <ul style="list-style-type: none"> a) mechanical stresses such as <ul style="list-style-type: none"> —stress limitation by implementation of correct calculation, construction and fastening methods as regards, for example, bolted assemblies and welded assemblies, —stress limitation by overload prevention (bursting disk, pressure-limiting valves, breakage points, torque-limiting devices, etc.), —avoiding fatigue in elements under variable stresses (notably cyclic stresses), and —static and dynamic balancing of rotating elements, b) materials and their properties such as <ul style="list-style-type: none"> —resistance to corrosion, ageing, abrasion and wear, —hardness, ductility, brittleness, —homogeneity, —toxicity, and —flammability, and c) emission values for <ul style="list-style-type: none"> —noise, —vibration, —hazardous substances, and —radiation. <p>When the reliability of particular components or assemblies is critical for safety (for example, ropes, chains, lifting accessories for lifting loads or persons), stress limits shall be multiplied by appropriate working coefficients.</p>	P	

Clause	Requirement-Test	Result	Verdict
6.2.4	Choice of appropriate technology		
	<p>One or more hazards can be eliminated or risks reduced by the choice of the technology to be used in certain applications such as the following:</p> <p>a) on machines intended for use in explosive atmospheres, using</p> <ul style="list-style-type: none"> —appropriately selected pneumatic or hydraulic control system and machine actuators, —intrinsically safe electrical equipment (see IEC 60079-11); <p>b) for particular products to be processed (for example, by a solvent), by using equipment that ensures the temperature will remain far below the flash point;</p> <p>c) the use of alternative equipment to avoid high noise levels, such as</p> <ul style="list-style-type: none"> —electrical instead of pneumatic equipment, —in certain conditions, water-cutting instead of mechanical equipment. 	P	
6.2.5	Applying principle of positive mechanical action		
	<p>Positive mechanical action is achieved when a moving mechanical component inevitably moves another component along with it, either by direct contact or via rigid elements. An example of this is positive opening operation of switching devices in an electrical circuit (see IEC 60947-5-1 and ISO 14119).</p>	P	
6.2.6	Provisions for stability		
	<p>Machines shall be designed so that they have sufficient stability to allow them to be used safely in their specified conditions of use. Factors to be taken into account include</p> <ul style="list-style-type: none"> —the geometry of the base, —the weight distribution, including loading, —the dynamic forces due to movements of parts of the machine, of the machine itself or of elements held by the machine which can result in an overturning moment, —vibration, —oscillations of the centre of gravity, —characteristics of the supporting surface in case of travelling or installation on different sites (ground conditions, slope, etc.), and —external forces, such as wind pressure and manual forces. <p>Stability shall be considered in all phases of the life cycle of the machine, including handling, travelling, installation, use, dismantling, disabling and scrapping.</p> <p>Other protective measures for stability relevant to safeguarding are given in 6.3.2.6.</p>	P	
6.2.7	Provisions for maintainability		
	<p>When designing a machine, the following maintainability factors shall be taken into account to enable maintenance of the machine:</p> <ul style="list-style-type: none"> —accessibility, taking into account the environment and the human body measurements, including the dimensions of the working clothes and tools used; —ease of handling, taking into account human capabilities; —limitation of the number of special tools and equipment. 	P	
6.2.8	Observing ergonomic principles		
	<p>Ergonomic principles shall be taken into account in designing machinery so as to reduce the mental or physical stress of, and strain on, the operator. These principles shall be considered when allocating functions to operator and machine (degree of automation) in the basic design.</p> <p>NOTE Also improved are the performance and reliability of operation and hence the reduction in the probability of errors at all stages of machine use.</p>	P	

Clause	Requirement-Test	Result	Verdict
	<p>Account shall be taken of body sizes likely to be found in the intended user population, strengths and postures, movement amplitudes, frequency of cyclic actions (see ISO 10075 and ISO 10075-2).</p> <p>All elements of the operator-machine interface, such as controls, signalling or data display elements shall be designed to be easily understood so that clear and unambiguous interaction between the operator and the machine is possible. See EN 614-1, EN 13861 and IEC 61310-1. The designer's attention is particularly drawn to following ergonomic aspects of machine design.</p> <p>a) Avoid the necessity for stressful postures and movements during the use of the machine (for example, providing facilities to adjust the machine to suit the various operators).</p> <p>b) Design machines, especially hand-held and mobile machines, so as to enable them to be operated easily, taking into account human effort, actuation of controls and hand, arm and leg anatomy.</p> <p>c) Limit as far as possible noise, vibration and thermal effects such as extreme temperatures.</p> <p>d) Avoid linking the operator's working rhythm to an automatic succession of cycles.</p> <p>e) Provide local lighting on or in the machine for the illumination of the working area and of adjusting, setting-up and frequent maintenance zones when the design features of the machine and/or its guards render the ambient lighting inadequate. Flicker, dazzling, shadows and stroboscopic effects shall be avoided if they can cause a risk. If the position or the lighting source has to be adjusted, its location shall be such that it does not cause any risk to persons making the adjustment.</p> <p>f) Select, locate and identify manual controls (actuators) so that</p> <ul style="list-style-type: none"> —they are clearly visible and identifiable, and appropriately marked where necessary (see 6.4.4), —they can be safely operated without hesitation or loss of time and without ambiguity (for example, a standard layout of controls reduces the possibility of error when an operator changes from a machine to another one of similar type having the same pattern of operation), —their location (for push-buttons) and their movement (for levers and hand wheels) are consistent with their effect (see IEC 61310-3), and —their operation cannot cause additional risk. <p>See also ISO 9355-3.</p>		
6.2.9	Electrical hazards		
	<p>For the design of the electrical equipment of machines, IEC 60204-1 gives general provisions about disconnection and switching of electrical circuits and for protection against electric shock. For requirements related to specific machines, see corresponding IEC standards (for example, IEC 61029, IEC 60745 or IEC 60335).</p>	P	
6.2.10	Pneumatic and hydraulic hazards		
	<p>Pneumatic and hydraulic equipment of machinery shall be designed so that</p> <ul style="list-style-type: none"> —the maximum rated pressure cannot be exceeded in the circuits (using, for example, pressure-limiting devices), —no hazard results from pressure fluctuations or increases, or from loss of pressure or vacuum, —no hazardous fluid jet or sudden hazardous movement of the hose (whiplash) results from leakage or component failures, —air receivers, air reservoirs or similar vessels (such as in gas-loaded accumulators) comply with the applicable design standard codes or regulations for these elements, —all elements of the equipment, especially pipes and hoses, are protected against harmful 	N	

Clause	Requirement-Test	Result	Verdict
--------	------------------	--------	---------

	<p>external effects,</p> <p>—as far as possible, reservoirs and similar vessels (for example, gas-loaded accumulators) are automatically depressurized when isolating the machine from its power supply (see 6.3.5.4) and, if not possible, means are provided for their isolation, local depressurizing and pressure indication (see also ISO 14118:2000, Clause 5), and</p> <p>—all elements which remain under pressure after isolation of the machine from its power supply are provided with clearly identified exhaust devices, and there is a warning label drawing attention to the necessity of depressurizing those elements before any setting or maintenance activity on the machine.</p>		
--	---	--	--

6.2.11 Applying inherently safe design measures to control systems

6.2.11.1	General
-----------------	----------------

	<p>The design measures of the control system shall be chosen so that their safety-related performance provides a sufficient amount of risk reduction (see ISO 13849-1 or IEC 62061). The correct design of machine control systems can avoid unforeseen and potentially hazardous machine behaviour.</p> <p>Typical causes of hazardous machine behaviour are</p> <ul style="list-style-type: none"> —an unsuitable design or modification (accidental or deliberate) of the control system logic, —a temporary or permanent defect or failure of one or several components of the control system, —a variation or a failure in the power supply of the control system, and —inappropriate selection, design and location of the control devices. <p>Typical examples of hazardous machine behaviour are</p> <ul style="list-style-type: none"> —unexpected start-up (see ISO 14118), —uncontrolled speed change, —failure to stop moving parts, —dropping or ejection of part of the machine or of a workpiece clamped by the machine, and —machine action resulting from inhibition (defeating or failure) of protective devices. <p>In order to prevent hazardous machine behaviour and to achieve safety functions, the design of control systems shall comply with the principles and methods presented in this subclause (6.2.11) and in 6.2.12.</p> <p>These principles and methods shall be applied singly or in combination as appropriate to the circumstances (see ISO 13849-1, IEC 60204-1 and IEC 62061).</p> <p>Control systems shall be designed to enable the operator to interact with the machine safely and easily. This requires one or several of the following solutions:</p> <ul style="list-style-type: none"> —systematic analysis of start and stop conditions; —provision for specific operating modes (for example, start-up after normal stop, restart after cycle interruption or after emergency stop, removal of the workpieces contained in the machine, operation of a part of the machine in case of a failure of a machine element); —clear display of the faults; —measures to prevent accidental generation of unexpected start commands (for example, shrouded start device) likely to cause dangerous machine behaviour (see ISO 14118:2000, Figure 1); 	P	
--	--	---	--

Clause	Requirement-Test	Result	Verdict
	<p>—maintained stop commands (for example, interlock) to prevent restarting that could result in dangerous machine behaviour (see ISO 14118:2000, Figure 1).</p> <p>An assembly of machines may be divided into several zones for emergency stopping, for stopping as a result of protective devices and/or for isolation and energy dissipation. The different zones shall be clearly defined and it shall be obvious which parts of the machine belong to which zone. Likewise, it shall be obvious which control devices (for example, emergency stop devices, supply disconnecting devices) and/or protective devices belong to which zone. The interfaces between zones shall be designed such that no function in one zone creates hazards in another zone which has been stopped for an intervention.</p> <p>Control systems shall be designed to limit the movements of parts of the machinery, the machine itself, or workpieces and/or loads held by the machinery, to the safe design parameters (for example, range, speed, acceleration, deceleration, load capacity). Allowance shall be made for dynamic effects (swinging of loads, etc.).</p> <p>For example:</p> <ul style="list-style-type: none"> —the travelling speed of mobile pedestrian controlled machinery other than remote-controlled shall be compatible with walking speed; —the range, speed, acceleration and deceleration of movements of the person-carrier and carrying vehicle for lifting persons shall be limited to non-hazardous values, taking into account the total reaction time of the operator and the machine; —the range of movements of parts of machinery for lifting loads shall be kept within specified limits. <p>When the machinery contains various elements that can be operated independently, the control system shall be designed to prevent risks arising out of a lack of coordination (for example, collision prevention system).</p>		
6.2.11.2	Starting of an internal power source/switching on an external power supply		
	<p>The starting of an internal power source or switching-on of an external power supply shall not result in a hazardous situation.</p> <p>For example:</p> <ul style="list-style-type: none"> —starting the internal combustion engine shall not lead to movement of a mobile machine; —connection to mains electricity supply shall not result in the starting of working parts of a machine. <p>See IEC 60204-1:2005, 7.5 (see also Annexes A and B).</p>	P	EN 60204-1
6.2.11.3	Starting/stopping of a mechanism		
	<p>The primary action for starting or accelerating the movement of a mechanism should be performed by the application or an increase of voltage or fluid pressure, or — if binary logic elements are considered — by passage from state 0 to state 1 (where state 1 represents the highest energy state).</p> <p>The primary action for stopping or slowing down should be performed by removal or reduction of voltage or fluid pressure, or — if binary logic elements are considered — by passage from state 1 to state 0 (where state 1 represents the highest energy state).</p> <p>In certain applications, such as high-voltage switchgear, this principle cannot be followed, in which case other measures should be applied to achieve the same level of confidence for the stopping or slowing down.</p>	P	

Clause	Requirement-Test	Result	Verdict
	When, in order for the operator to maintain permanent control of deceleration, this principle is not observed (for example, a hydraulic braking device of a self-propelled mobile machine), the machine shall be equipped with a means of slowing and stopping in case of failure of the main braking system.		
6.2.11.4	Restart after power interruption		
	If a hazard could be generated, the spontaneous restart of a machine when it is re-energized after power interruption shall be prevented (for example, by use of a self-maintained relay, contactor or valve).	P	
6.2.11.5	Interruption of power supply		
	Machinery shall be designed to prevent hazardous situations resulting from interruption or excessive fluctuation of the power supply. At least the following requirements shall be met: —the stopping function of the machinery shall remain; —all devices whose permanent operation is required for safety shall operate in an effective way to maintain safety (for example, locking, clamping devices, cooling or heating devices, power-assisted steering of self-propelled mobile machinery); —parts of machinery or workpieces and/or loads held by machinery which are liable to move as a result of potential energy shall be retained for the time necessary to allow them to be safely lowered.	P	
6.2.11.6	Use of automatic monitoring		
	Automatic monitoring is intended to ensure that a safety function or functions implemented by a protective measure do not fail to be performed if the ability of a component or an element to perform its function is diminished, or if the process conditions are changed such that hazards are generated. Automatic monitoring either detects a fault immediately or carries out periodic checks so that a fault is detected before the next demand upon the safety function. In either case, the protective measure can be initiated immediately or delayed until a specific event occurs (for example, the beginning of the machine cycle). The protective measure may be, for example, —the stopping of the hazardous process, —preventing the restart of this process after the first stop following the failure, or —the triggering of an alarm.	P	
6.2.11.7	Safety functions implemented by programmable electronic control systems		
6.2.11.7.1	General		
	A control system that includes programmable electronic equipment (for example, programmable controllers) can, where appropriate, be used to implement safety functions at machinery. Where a programmable electronic control system is used, it is necessary to consider its performance requirements in relation to the requirements for the safety functions. The design of the programmable electronic control system shall be such that the probability of random hardware failures and the likelihood of systematic failures that can adversely affect the performance of the safety-related control function(s) is sufficiently low. Where a programmable electronic control system performs a monitoring function, the system behavior on detection of a fault shall be considered (see also the IEC 61508 series for further guidance). NOTE Both ISO 13849-1 and IEC 62061, specific to machinery safety, provide guidance applicable to programmable electronic control systems.	P	

Clause	Requirement-Test	Result	Verdict
	The programmable electronic control system should be installed and validated to ensure that the specified performance [for example, safety integrity level (SIL) in IEC 61508] for each safety function has been achieved. Validation comprises testing and analysis (for example, static, dynamic or failure analysis) to show that all parts interact correctly to perform the safety function and that unintended functions do not occur.		
6.2.11.7.2	Hardware aspects		
	The hardware (including, for example, sensors, actuators and logic solvers) shall be selected, and/or designed and installed, to meet both the functional and performance requirements of the safety function(s) to be performed, in particular, by means of —architectural constraints (the configuration of the system, its ability to tolerate faults, its behaviour on detection of a fault, etc.), —selection, and/or design, of equipment and devices with an appropriate probability of dangerous random hardware failure, and —the incorporation of measures and techniques within the hardware so as to avoid systematic failures and control systematic faults.	N	
6.2.11.7.3	Software aspects		
	The software, including internal operating software (or system software) and application software, shall be designed so as to satisfy the performance specification for the safety functions (see also IEC 61508-3). Application software should not be reprogrammable by the user. This may be achieved by use of embedded software in a non-reprogrammable memory [for example, micro-controller, application-specific integrated circuit (ASIC)]. When the application requires reprogramming by the user, the access to the software dealing with safety functions should be restricted (for example, by locks or passwords for the authorized persons).	N	
6.2.11.8	Principles relating to manual control		
	These are as follows. a) Manual control devices shall be designed and located according to the relevant ergonomic principles given in 6.2.8, item f). b) A stop control device shall be placed near each start control device. Where the start/stop function is performed by means of a hold-to-run control, a separate stop control device shall be provided when a risk can result from the hold-to-run control device failing to deliver a stop command when released. c) Manual controls shall be located out of reach of the danger zones (see IEC 61310-3), except for certain controls where, of necessity, they are located within a danger zone, such as emergency stop or teach pendant. d) Whenever possible, control devices and control positions shall be located so that the operator is able to observe the working area or hazard zone. 1) The driver of a ride-on mobile machine shall be able to actuate all control devices required to operate the machine from the driving position, except for functions which can be controlled more safely from other positions. 2) On machinery intended for lifting persons, controls for lifting and lowering and, if appropriate, for moving the carrier shall generally be located in the carrier. If safe operation requires controls to be situated outside the carrier, the operator in the carrier shall be provided with the	P	

Clause	Requirement-Test	Result	Verdict
	<p>means of preventing hazardous movements.</p> <p>e) If it is possible to start the same hazardous element by means of several controls, the control circuit shall be so arranged that only one control is effective at a given time.</p> <p>This applies especially to machines which can be manually controlled by means of, among others, a portable control unit (such as a teach pendant), with which the operator can enter danger zones.</p> <p>f) Control actuators shall be designed or guarded so that their effect, where a risk is involved, cannot occur without intentional operation (see ISO 9355-1, ISO 9355-3 and ISO 447).</p> <p>g) For machine functions whose safe operation depends on permanent, direct control by the operator, measures shall be implemented to ensure the presence of the operator at the control position (for example, by the design and location of control devices).</p> <p>h) For cableless control, an automatic stop shall be performed when correct control signals are not received, including loss of communication (see IEC 60204-1).</p>		
6.2.11.9	Control mode for setting, teaching, process changeover, fault-finding, cleaning or maintenance		
	<p>Where, for setting, teaching, process changeover, fault-finding, cleaning or maintenance of machinery, a guard has to be displaced or removed and/or a protective device has to be disabled, and where it is necessary for the purpose of these operations for the machinery or part of the machinery to be put into operation, the safety of the operator shall be achieved using a specific control mode which simultaneously</p> <p>a) disables all other control modes,</p> <p>b) permits operation of the hazardous elements only by continuous actuation of an enabling device, a two-hand control device or a hold-to-run control device,</p> <p>c) permits operation of the hazardous elements only in reduced risk conditions (for example, reduced speed, reduced power/force, step-by-step, for example, with a limited movement control device), and</p> <p>d) prevents any operation of hazardous functions by voluntary or involuntary action on the machine's sensors.</p> <p>NOTE For some special machinery other protective measures can be appropriate.</p> <p>This control mode shall be associated with one or more of the following measures:</p> <p>—restriction of access to the danger zone as far as possible;</p> <p>—emergency stop control within immediate reach of the operator;</p> <p>—portable control unit (teach pendant) and/or local controls (allowing sight of the controlled elements).</p> <p>See IEC 60204-1.</p>	P	
6.2.11.10	Selection of control and operating modes		
	<p>If machinery has been designed and built to allow for its use in several control or operating modes requiring different protective measures and/or work procedures (for example, to allow for adjustment, setting, maintenance, inspection), it shall be fitted with a mode selector which can be locked in each position. Each position of the selector shall be clearly identifiable and shall exclusively allow one control or operating mode.</p> <p>The selector may be replaced by another selection means which restricts the use of certain functions of the machinery to certain categories of operators (for example, access codes for certain numerically controlled functions).</p>	P	
6.2.11.11	Applying measures to achieve electromagnetic compatibility (EMC)		

Clause	Requirement-Test	Result	Verdict
	For guidance on electromagnetic compatibility, see IEC 60204-1 and IEC 61000-6.	N	
6.2.11.12	Provision of diagnostic systems to aid fault-finding		
	Diagnostic systems to aid fault-finding should be included in the control system so that there is no need to disable any protective measure. NOTE Such systems not only improve availability and maintainability of machinery, they also reduce the exposure of maintenance staff to hazards.	N	
6.2.12 Minimizing probability of failure of safety functions			
6.2.12.1	General		
	Safety of machinery is not only dependent on the reliability of the control systems but also on the reliability of all parts of the machine. The continued operation of the safety functions is essential for the safe use of the machine. This can be achieved by the measures given in 6.2.12.2 to 6.2.12.4.	P	
6.2.12.2	Use of reliable components		
	"Reliable components" means components which are capable of withstanding all disturbances and stresses associated with the usage of the equipment in the conditions of intended use (including the environmental conditions), for the period of time or the number of operations fixed for the use, with a low probability of failures generating a hazardous malfunctioning of the machine. Components shall be selected taking into account all factors mentioned above (see also 6.2.13). NOTE 1 "Reliable components" is not a synonym for "well-ried components" (see ISO 13849-1:2006, 6.2.4). NOTE 2 Environmental conditions for consideration include impact, vibration, cold, heat, moisture, dust, corrosive and/or abrasive substances, static electricity and magnetic and electric fields. Disturbances which can be generated by those conditions include insulation failures and temporary or permanent failures in the function of control system components.	P	
6.2.12.3	Use of "oriented failure mode" components		
	"Oriented failure mode" components or systems are those in which the predominant failure mode is known in advance and which can be used so that the effect of such a failure on the machine function can be predicted. NOTE In some cases, it will be necessary to take additional measures to limit the negative effects of such a failure. The use of such components should always be considered, particularly in cases where redundancy (see 6.2.12.4) is not employed.	N	
6.2.12.4	Duplication (or redundancy) of components or subsystems		
	In the design of safety-related parts of the machine, duplication (or redundancy) of components may be used so that, if one component fails, another component or components continue to perform the respective function(s), thereby ensuring that the safety function remains available. In order to allow the proper action to be initiated, component failure shall be detected by automatic monitoring (see 6.2.11.6) or in some circumstances by regular inspection, provided that the inspection interval is shorter than the expected lifetime of the components. Diversity of design and/or technology can be used to avoid common cause failures (for example, from electromagnetic disturbance) or common mode failures.	N	
6.2.13	Limiting exposure to hazards through reliability of equipment		

Clause	Requirement-Test	Result	Verdict
	<p>Increased reliability of all component parts of machinery reduces the frequency of incidents requiring intervention, thereby reducing exposure to hazards.</p> <p>This applies to power systems (operative part, see Annex A) as well as to control systems, and to safety functions as well as to other functions of machinery.</p> <p>Safety-related components (for example, certain sensors) of known reliability shall be used.</p> <p>The elements of guards and of protective devices shall be especially reliable, as their failure can expose persons to hazards, and also because poor reliability would encourage attempts to defeat them.</p>	P	
6.2.14	Limiting exposure to hazards through mechanization or automation of loading (feeding)/unloading (removal) operations		
	<p>Mechanization and automation of machine loading/unloading operations and, more generally, of handling operations — of workpieces, materials or substances — limits the risk generated by these operations by reducing the exposure of persons to hazards at the operating points.</p> <p>Automation can be achieved by, for example, robots, handling devices, transfer mechanisms and air-blast equipment. Mechanization can be achieved by, for example, feeding slides, push-rods and hand-operated indexing tables.</p> <p>While automatic feeding and removal devices have much to offer in preventing accidents to machine operators, they can create danger when any faults are being corrected. Care shall be taken to ensure that the use of these devices does not introduce further hazards, such as trapping or crushing, between the devices and parts of the machine or workpieces/materials being processed. Suitable safeguards (see 6.3) shall be provided if this cannot be ensured.</p> <p>Automatic feeding and removal devices with their own control systems and the control system of the associated machine shall be interconnected after thorough study of how all safety functions are performed in all the control and operation modes of the entire equipment.</p>	N	
6.2.15	Limiting exposure to hazards through location of setting and maintenance points outside danger zones		
	<p>The need for access to danger zones shall be minimized by locating maintenance, lubrication and setting points outside these zones.</p>	N	
6.3 Safeguarding and complementary protective measures			
6.3.1	General		
	<p>Guards and protective devices shall be used to protect persons whenever an inherently safe design measure does not reasonably make it possible either to remove hazards or to sufficiently reduce risks. Complementary protective measures involving additional equipment (for example, emergency stop equipment) may have to be implemented.</p> <p>NOTE The different kinds of guards and protective devices are defined in 3.27 and 3.28.</p> <p>Certain safeguards may be used to avoid exposure to more than one hazard.</p> <p>EXAMPLE A fixed guard preventing access to a zone where a mechanical hazard is present used to reduce noise levels and collect toxic emissions.</p>	P	
6.3.2 Selection and implementation of guards and protective devices			
6.3.2.1	General		
	<p>This subclause gives guidelines for the selection and the implementation of guards and protective devices the primary purpose of which is to protect persons against hazards generated by moving parts, according to the nature of those parts (see Figure 4) and to the need for access to the danger zone(s).</p> <p>The exact choice of a safeguard for a particular machine shall be made on the basis of the risk</p>	P	

Clause	Requirement-Test	Result	Verdict
	<p>assessment for that machine.</p> <p>In selecting an appropriate safeguard for a particular type of machinery or hazard zone, it shall be borne in mind that a fixed guard is simple and shall be used where the access of an operator into a danger zone is not required during the normal operation (operation without malfunction) of the machinery.</p> <p>As the need for frequency of access increases, this inevitably leads to the fixed guard not being replaced. This requires the use of an alternative protective measure (movable interlocking guard, sensitive protective equipment).</p> <p>A combination of safeguards can sometimes be required. For example, where, in conjunction with a fixed guard, a mechanical loading (feeding) device is used to feed a workpiece into a machine, thereby removing the need for access to the primary hazard zone, a trip device can be required to protect against the secondary drawing-in or shearing hazard between the mechanical loading (feeding) device, when reachable, and the fixed guard.</p> <p>Consideration shall be given to the enclosure of control positions or intervention zones to provide combined protection against several hazards including</p> <ul style="list-style-type: none"> a) hazards from falling or ejected objects, using, for example, protection in the form of a falling object protection structure (FOPS), b) emission hazards (protection against noise, vibration, radiation, substances hazardous to health, etc.), c) hazards due to the environment (protection against heat, cold, foul weather, etc.), d) hazards due to tipping over or rolling over of machinery, using, for example, protection in the form of roll-over or tip-over protection structures (ROPS and TOPS). <p>The design of enclosed work stations, such as cabs and cabins, shall take into account ergonomic principles concerning visibility, lighting, atmospheric conditions, access, posture.</p>		
6.3.2.2	Where access to the hazard zone is not required during normal operation		
	<p>Where access to the hazard zone is not required during normal operation of the machinery, safeguards should be selected from the following:</p> <ul style="list-style-type: none"> a) fixed guards (see also ISO 14120); b) interlocking guards with or without guard locking (see also 6.3.3.2.3, ISO 14119 and ISO 14120); c) self-closing guards (see ISO 14120:2002, 3.3.2); d) sensitive protective equipment, such as electrosensitive protective equipment (see IEC 61496) or pressure-sensitive protective devices (see ISO 13856). 	N	
6.3.2.3	Where access to the hazard zone is required during normal operation		
	<p>Where access to the hazard zone is required during normal operation of the machinery, safeguards should be selected from the following:</p> <ul style="list-style-type: none"> a) interlocking guards with or without guard locking (see also ISO 14119, ISO 14120 and 6.3.3.2.3 of this document); b) sensitive protective equipment, such as electrosensitive protective equipment (see IEC 61496); c) adjustable guards; d) self-closing guards (see ISO 14120:2002, 3.3.2); e) two-hand control devices (see ISO 13851); f) interlocking guards with a start function (control guard) (see 6.3.3.2.5). 	P	

Clause	Requirement-Test	Result	Verdict
6.3.2.4	<p>Where access to the hazard zone is required for machine setting, teaching, process changeover, fault-finding, cleaning or maintenance</p>		
	<p>production operator also ensure the protection of personnel carrying out setting, teaching, process changeover, fault-finding, cleaning or maintenance, without hindering them in the performance of their task.</p> <p>Such tasks shall be identified and considered in the risk assessment as parts of the use of the machine (see 5.2).</p> <p>NOTE Isolation and energy dissipation for machine shut-down (see 6.3.5.4, and also ISO 14118:2000, 4.1 and Clause 5) ensure the highest level of safety when carrying out tasks (especially maintenance and repair tasks) that do not require the machine to remain connected to its power supply.</p>	P	
6.3.2.5 Selection and implementation of sensitive protective equipment¹⁾			
6.3.2.5.1	<p>Selection</p>		
	<p>Due to the great diversity of the technologies on which their detection function is based, all types of sensitive protective equipment are far from being equally suitable for safety applications. The following provisions are intended to provide the designer with criteria for selecting, for each application, the most suitable device(s).</p> <p>Types of sensitive protective equipment include</p> <ul style="list-style-type: none"> —light curtains, —scanning devices, for example, laser scanners, —pressure-sensitive mats, and —trip bars, trip wires. <p>Sensitive protective equipment can be used</p> <ul style="list-style-type: none"> —for tripping purposes, —for presence sensing, —for both tripping and presence sensing, or —to re-initiate machine operation — a practice subject to stringent conditions. <p>NOTE Some types of sensitive protective equipment can be unsuitable either for presence sensing or for tripping purposes.</p> <p>The following characteristics of the machinery, among others, can preclude the sole use of sensitive protective equipment:</p> <ul style="list-style-type: none"> —tendency for the machinery to eject materials or component parts; —necessity to guard against emissions (noise, radiation, dust, etc.); —erratic or excessive machine stopping time; —inability of a machine to stop part-way through a cycle. 	P	
6.3.2.5.2	<p>Implementation</p>		
	<p>Consideration should be given to</p> <ol style="list-style-type: none"> a) the size, characteristics and positioning of the detection zone (see ISO 13855, which deals with the positioning of some types of sensitive protective equipment), b) the reaction of the device to fault conditions (see IEC 61496 for electrosensitive protective equipment), c) the possibility of circumvention, and d) detection capability and its variation over the course of time (as a result, for example, of its susceptibility to different environmental conditions such as the presence of reflecting surfaces, 	P	

Clause	Requirement-Test	Result	Verdict
	<p>other artificial light sources and sunlight or impurities in the air).</p> <p>NOTE 1 IEC 61496 defines the detection capability of electrosensitive protective equipment. Sensitive protective equipment shall be integrated in the operative part and associated with the control system of the machine so that</p> <ul style="list-style-type: none"> —a command is given as soon as a person or part of a person is detected, —the withdrawal of the person or part of a person detected does not, by itself, restart the hazardous machine function(s), and therefore the command given by the sensitive protective equipment is maintained by the control system until a new command is given, —restarting the hazardous machine function(s) results from the voluntary actuation by the operator of a control device placed outside the hazard zone, where this zone can be observed by the operator, —the machine cannot operate during interruption of the detection function of the sensitive protective equipment, except during muting phases, and —the position and the shape of the detection field prevents, possibly together with fixed guards, a person or part of a person from entering or being present in the hazard zone without being detected. <p>NOTE 2 Muting is the temporary automatic suspension of a safety function(s) by safety-related parts of the control system (see ISO 13849-1).</p> <p>For detailed consideration of the fault behaviour of, for example, active optoelectronic protective devices, IEC 61496 should be taken into account.</p>		
6.3.2.5.3	Additional requirements for sensitive protective equipment when used for cycle initiation		
	<p>In this exceptional application, the starting of the machine cycle is initiated by the withdrawal of a person or of the detected part of a person from the sensing field of the sensitive protective equipment, without any additional start command, hence deviating from the general requirement given in the second point of the dashed list in 6.3.2.5.2, above. After switching on the power supply, or when the machine has been stopped</p> <p>by the tripping function of the sensitive protective equipment, the machine cycle shall be initiated only by voluntary actuation of a start control.</p> <p>Cycle initiation by sensitive protective equipment shall be subject to the following conditions:</p> <ol style="list-style-type: none"> a) only active optoelectronic protective devices (AOPDs) complying with IEC 61496 series shall be used; b) the requirements for an AOPD used as a tripping and presence-sensing device (see IEC 61496) are satisfied — in particular, location, minimum distance (see ISO 13855), detection capability, reliability and monitoring of control and braking systems; c) the cycle time of the machine is short and the facility to re-initiate the machine upon clearing of the sensing field is limited to a period commensurate with a single normal cycle; d) entering the sensing field of the AOPD(s) or opening interlocking guards is the only way to enter the hazard zone; e) if there is more than one AOPD safeguarding the machine, only one of the AOPDs is capable of cycle re-initiation; f) with regard to the higher risk resulting from automatic cycle initiation, the AOPD and the associated control system comply with a higher safety-related performance than under normal conditions. <p>NOTE 1 The hazard zone as referred to in d) is any zone where the hazardous function</p>	P	

Clause	Requirement-Test	Result	Verdict
	(including ancillary equipment and transmission elements) is initiated by clearing of the sensing field. NOTE 2 See also IEC/TS 62046.		
6.3.2.6	Protective measures for stability		
	If stability cannot be achieved by inherently safe design measures such as weight distribution (see 6.2.6), it shall be maintained by the use of protective measures such as —anchorage bolts, —locking devices, —movement limiters or mechanical stops, —acceleration or deceleration limiters, —load limiters, and —alarms warning of the approach to stability or tipping limits.	P	
6.3.2.7	Other protective devices		
	error of the operator can generate a hazardous situation, this machine shall be equipped with the necessary devices to enable the operation to remain within specified limits, in particular —when the operator has insufficient visibility of the hazard zone, —when the operator lacks knowledge of the actual value of a safety-related parameter (distance, speed, mass, angle, etc.), and — when hazards can result from operations other than those controlled by the operator. The necessary devices include a) devices for limiting parameters of movement (distance, angle, velocity, acceleration), b) overloading and moment limiting devices, c) devices to prevent collisions or interference with other machines, d) devices for preventing hazards to pedestrian operators of mobile machinery or other pedestrians, e) torque limiting devices, and breakage points to prevent excessive stress of components and assemblies, f) devices for limiting pressure or temperature, g) devices for monitoring emissions, h) devices to prevent operation in the absence of the operator at the control position, i) devices to prevent lifting operations unless stabilizers are in place, j) devices to limit inclination of the machine on a slope, and k) devices to ensure that components are in a safe position before travelling. Automatic protective measures triggered by such devices that take operation of the machinery out of the control of the operator (for example, automatic stop of hazardous movement) should be preceded or accompanied by a warning signal to enable the operator to take appropriate action (see 6.4.3).	P	
6.3.3 Requirements for design of guards and protective devices			
6.3.3.1	General requirements		
	Guards and protective devices shall be designed to be suitable for the intended use, taking into account mechanical and other hazards involved. Guards and protective devices shall be compatible with the working environment of the machine and designed so that they cannot be easily defeated. They shall provide the minimum possible interference with activities during operation and other phases of machine life, in order to reduce any incentive to defeat them.	P	

Clause	Requirement-Test	Result	Verdict
	<p>NOTE For additional information, see ISO 14120, ISO 13849-1, ISO 13851, ISO 14119, ISO 13856, IEC 61496 and IEC 62061.</p> <p>Guards and protective devices shall</p> <ul style="list-style-type: none"> a) be of robust construction, b) not give rise to any additional hazard, c) not be easy to bypass or render non-operational, d) be located at an adequate distance from the danger zone (see ISO 13855 and ISO 13857), e) cause minimum obstruction to the view of the production process, and f) enable essential work to be carried out for the installation and/or replacement of tools and for maintenance by allowing access only to the area where the work has to be carried out — if possible, without the guard having to be removed or protective device having to be disabled. <p>For openings in the guards, see ISO 13857.</p>		
6.3.3.2 Requirements for guards			
6.3.3.2.1	Functions of guards		
	<p>The functions that guards can achieve are</p> <ul style="list-style-type: none"> —prevention of access to the space enclosed by the guard, and/or —containment/capture of materials, workpieces, chips, liquids which can be ejected or dropped by the machine, and reduction of emissions (noise, radiation, hazardous substances such as dust, fumes, gases) that can be generated by the machine. <p>Additionally, they could need to have particular properties relating to electricity, temperature, fire, explosion, vibration, visibility (see ISO 14120) and operator position ergonomics (for example, usability, operator's movements, postures, repetitive movements).</p>	P	
6.3.3.2.2	Requirements for fixed guards		
	<p>Fixed guards shall be securely held in place either</p> <ul style="list-style-type: none"> —permanently (for example by welding), or —by means of fasteners (screws, nuts) making removal/opening impossible without using tools; they should not remain closed without their fasteners (see ISO 14120). <p>NOTE A fixed guard can be hinged to assist in its opening.</p>	P	
6.3.3.2.3	Requirements for movable guards		
	<p>Movable guards which provide protection against hazards generated by moving transmission parts shall</p> <ul style="list-style-type: none"> a) as far as possible when open remain fixed to the machinery or other structure (generally by means of hinges or guides), and b) be interlocking (with guard locking when necessary) (see ISO 14119). <p>See Figure 4.</p> <p>Movable guards against hazards generated by non-transmission moving parts shall be designed and associated with the machine control system so that</p> <ul style="list-style-type: none"> —moving parts cannot start up while they are within the operator's reach and the operator cannot reach moving parts once they have started up, with this able to be achieved by interlocking guards, with guard locking when necessary, —they can be adjusted only by an intentional action, such as the use of a tool or a key, and —the absence or failure of one of their components either prevents starting of the moving parts or stops them, with this able to be achieved by automatic monitoring (see 6.2.11.6). <p>See Figure 4 and ISO 14119.</p>	P	

Clause	Requirement-Test	Result	Verdict
6.3.3.2.4	Requirements for adjustable guards		
	Adjustable guards may only be used where the hazard zone cannot for operational reasons be completely enclosed. Manually adjustable guards shall be —designed so that the adjustment remains fixed during a given operation, and —readily adjustable without the use of tools.	P	
6.3.3.2.5	Requirements for interlocking guards with a start function (control guards)		
	An interlocking guard with a start function may only be used provided that a) all requirements for interlocking guards are satisfied (see ISO 14119), b) the cycle time of the machine is short, c) the maximum opening time of the guard is preset to a low value (for example, equal to the cycle time) and, when this time is exceeded, the hazardous function(s) cannot be initiated by the closing of the interlocking guard with a start function and resetting is necessary before restarting the machine, d) the dimensions or shape of the machine do not allow a person, or part of a person, to stay in the hazard zone or between the hazard zone and the guard while the guard is closed (see ISO 14120), e) all other guards, whether fixed (removable type) or movable, are interlocking guards, f) the interlocking device associated with the interlocking guard with a start function is designed such that —for example, by duplication of position detectors and use of automatic monitoring (see 6.2.11.6) — its failure cannot lead to an unintended/unexpected start-up, and g) the guard is securely held open (for example, by a spring or counterweight) such that it cannot initiate a start while falling by its own weight.	P	
6.3.3.2.6	Hazards from guards		
	Care shall be taken to prevent hazards which could be generated by —the guard construction (sharp edges or corners, material, noise emission, etc.), —the movements of the guards (shearing or crushing zones generated by power-operated guards and by heavy guards which are liable to fall).	P	
6.3.3.3	Technical characteristics of protective devices		
	Protective devices shall be selected or designed and connected to the control system such that correct implementation of their safety function(s) is ensured. Protective devices shall be selected on the basis of their having met the appropriate product standard (for example, IEC 61496 for active optoelectronic protective devices) or shall be designed according to one or several of the principles formulated in ISO 13849-1 or IEC 62061. Protective devices shall be installed and connected to the control system so that they cannot be easily defeated.	P	
6.3.3.4	Provisions for alternative types of safeguards		
	Provisions should be made to facilitate the fitting of alternative types of safeguards on machinery where it is known that it will be necessary to change the safeguards because of the range of work to be carried out.	P	
6.3.4	Safeguarding to reduce emissions		
6.3.4.1	General		
	If the measures for the reduction of emissions at source specified in 6.2.2.2 are not adequate, the machine shall be provided with additional protective measures (see 6.3.4.2 to 6.3.4.5).	N	

Standard: EN 60204-1:2006/AC: 2010, EN ISO 12100:2010

Clause	Requirement-Test	Result	Verdict
6.3.4.2	Noise		
	Additional protective measures against noise include —enclosures (see ISO 15667), —screens fitted to the machine, and —silencers (see ISO 14163).	N	
6.3.4.3	Vibration		
	Additional protective measures against vibration include —vibration isolators, such as damping devices placed between the source and the exposed person, —resilient mounting, and —suspended seats. For measures for vibration isolation of stationary industrial machinery see EN 1299.	N	
6.3.4.4	Hazardous substances		
	Additional protective measures against hazardous substances include —encapsulation of the machine (enclosure with negative pressure), —local exhaust ventilation with filtration, —wetting with liquids, and —special ventilation in the area of the machine (air curtains, cabins for operators). See ISO 14123-1.	N	
6.3.4.5	Radiation		
	Additional protective measures against radiation include —use of filtering and absorption, and —use of attenuating screens or guards.	N	
6.3.5	Complementary protective measures		
6.3.5.1	General		
	Protective measures which are neither inherently safe design measures, nor safeguarding (implementation of guards and/or protective devices), nor information for use, could have to be implemented as required by the intended use and the reasonably foreseeable misuse of the machine. Such measures include, but are not limited to, those dealt with in 6.3.5.2 to 6.3.5.6.	P	
6.3.5.2	Components and elements to achieve emergency stop function		
	If, following a risk assessment, a machine needs to be fitted with components and elements to achieve an emergency stop function for enabling actual or impending emergency situations to be averted, the following requirements apply: —the actuators shall be clearly identifiable, clearly visible and readily accessible; —the hazardous process shall be stopped as quickly as possible without creating additional hazards, but if this is not possible or the risk cannot be reduced, it should be questioned whether implementation of an emergency stop function is the best solution; —the emergency stop control shall trigger or permit the triggering of certain safeguard movements where necessary. NOTE For more detailed provisions, see ISO 13850. Once active operation of the emergency stop device has ceased following an emergency stop command, the effect of this command shall be sustained until it is reset. This reset shall be possible only at the location where the emergency stop command has been initiated. The reset of the device shall not restart the machinery, but shall only permit restarting.	P	

Clause	Requirement-Test	Result	Verdict
	More details for the design and selection of electrical components and elements to achieve the emergency stop function are provided in IEC 60204.		
6.3.5.3	Measures for the escape and rescue of trapped persons		
	Measures for the escape and rescue of trapped persons may consist, among others, of —escape routes and shelters in installations generating operator-trapping hazards, —arrangements for moving some elements by hand, after an emergency stop, —arrangements for reversing the movement of some elements, —anchorage points for descender devices, —means of communication to enable trapped operators to call for help.	P	
6.3.5.4	Measures for isolation and energy dissipation		
	Machines shall be equipped with the technical means to achieve isolation from power supply(ies) and dissipation of stored energy by means of the following actions: a) isolating (disconnecting, separating) the machine (or defined parts of the machine) from all power supplies; b) locking (or otherwise securing) all the isolating units in the isolating position; c) dissipating or, if this is not possible or practicable, restraining (containing) any stored energy which can give rise to a hazard; d) verifying, by means of safe working procedures, that the actions taken according to a), b) and c) above have produced the desired effect. See ISO 14118:2000, Clause 5, and IEC 60204-1:2005, 5.5 and 5.6.	P	
6.3.5.5	Provisions for easy and safe handling of machines and their heavy component parts		
	Machines and their component parts which cannot be moved or transported by hand shall be provided or be capable of being provided with suitable attachment devices for transport by means of lifting gear. These attachments may be, among others, —standardized lifting appliances with slings, hooks, eyebolts, or tapped holes for appliance fixing, —appliances for automatic grabbing with a lifting hook when attachment is not possible from the ground, —fork locating devices for machines to be transported by a lift truck, —lifting and stowing gear and appliances integrated into the machine. Parts of machinery which can be removed manually in operation shall be provided with means for their safe removal and replacement. See also 6.4.4 c), item 3).	P	
6.3.5.6	Measures for safe access to machinery		
	Machinery shall be so designed as to enable operation and all routine tasks relating to setting and/or maintenance to be carried out as far as possible by a person remaining at ground level. Where this is not possible, machines shall have built-in platforms, stairs or other facilities to provide safe access for those tasks; however, care should be taken to ensure that such platforms or stairs do not give access to danger zones of machinery. The walking areas shall be made from materials which remain as slip resistant as practicable under working conditions and, depending on the height from the ground, shall be provided with suitable guard-rails (see ISO 14122-3). In large automated installations, particular attention shall be given to safe means of access, such	P	

Clause	Requirement-Test	Result	Verdict
	<p>as walkways, conveyor bridges or crossover points.</p> <p>Means of access to parts of machinery located at height shall be provided with collective means of protection against falls (for example, guard-rails for stairways, stepladders and platforms and/or safety cages for ladders).</p> <p>As necessary, anchorage points for personal protective equipment against falls from height shall also be provided (for example, in carriers of machinery for lifting persons or with elevating control stations).</p> <p>Openings shall, whenever possible, open towards a safe position. They shall be designed to prevent hazards due to unintended opening.</p> <p>The necessary aids for access shall be provided (steps, handholds, etc.). Control devices shall be designed and located to prevent their being used as aids for access.</p> <p>When machinery for lifting goods and/or persons includes landings at fixed levels, these shall be equipped with interlocking guards for preventing falls when the platform is not present at a level. Movement of the lifting platform shall be prevented while the guards are open.</p> <p>For detailed provisions see ISO 14122.</p>		
6.4 Information for use			
6.4.1	General requirements		
6.4.1.1	<p>Drafting information for use is an integral part of the design of a machine (see Figure 2). Information for use consists of communication links, such as texts, words, signs, signals, symbols or diagrams, used separately or in combination to convey information to the user.</p> <p>Information for use is intended for professional and/or non-professional users.</p> <p>NOTE See also IEC 62079 for structuring and presentation of information for use.</p>	P	
6.4.1.2	<p>Information shall be provided to the user about the intended use of the machine, taking into account, notably, all its operating modes.</p> <p>The information shall contain all directions required to ensure safe and correct use of the machine. With this in view, it shall inform and warn the user about residual risk.</p> <p>The information shall indicate, as appropriate,</p> <ul style="list-style-type: none"> —the need for training, —the need for personal protective equipment, and —the possible need for additional guards or protective devices (see Figure 2, Footnote d). <p>It shall not exclude uses of the machine that can reasonably be expected from its designation and description and shall also warn about the risk which would result from using the machine in other ways than the ones described in the information, especially considering its reasonably foreseeable misuse.</p>	P	
6.4.1.3	<p>Information for use shall cover, separately or in combination, transport, assembly and installation, commissioning, use of the machine (setting, teaching/programming or process changeover, operation, cleaning, fault-finding and maintenance) and, if necessary, dismantling, disabling and scrapping.</p>	P	
6.4.2	Location and nature of information for use		
	<p>Depending on the risk, the time when the information is needed by the user and the machine design, it shall be decided whether the information — or parts thereof — are to be given</p> <ul style="list-style-type: none"> a) in/on the machine itself (see 6.4.3 and 6.4.4), b) in accompanying documents (in particular instruction handbook, see 6.4.5), c) on the packaging, 	P	

Clause	Requirement-Test	Result	Verdict
--------	------------------	--------	---------

	<p>d) by other means such as signals and warnings outside the machine.</p> <p>Standardized phrases shall be considered where important messages such as warnings are given (see also IEC 62079).</p>		
--	--	--	--

6.4.3 Signals and warning devices

<p>6.4.3</p>	<p>Visual signals, such as flashing lights and audible signals such as sirens may be used to warn of an impending hazardous event such as machine start-up or overspeed. Such signals may also be used to warn the operator before the triggering of automatic protective measures (see 6.3.2.7).</p> <p>It is essential that these signals</p> <ul style="list-style-type: none"> a) be emitted before the occurrence of the hazardous event, b) be unambiguous, c) be clearly perceived and differentiated from all other signals used, and d) be clearly recognized by the operator and other persons. <p>The warning devices shall be designed and located such that checking is easy. The information for use shall prescribe regular checking of warning devices.</p> <p>The attention of designers is drawn to the possibility of "sensorial saturation", which can result from too many visual and/or acoustic signals and which can also lead to defeating the warning devices.</p> <p>NOTE Consultation of the user on this subject is often necessary.</p>	<p>P</p>	
---------------------	---	----------	--

6.4.4 Markings, signs (pictograms) and written warnings

<p>6.4.4</p>	<p>Machinery shall bear all markings which are necessary</p> <ul style="list-style-type: none"> a) for its unambiguous identification, including at least <ul style="list-style-type: none"> 1) the name and address of the manufacturer, 2) the designation of series or type, and 3) the serial number, if any, b) in order to indicate its compliance with mandatory requirements, <ul style="list-style-type: none"> comprising <ul style="list-style-type: none"> 1) marking, and 2) written indications, such as the authorized representative of the manufacturer, designation of the machinery, year of construction, and intended use in potentially explosive atmospheres), c) for its safe use, for example, <ul style="list-style-type: none"> 1) maximum speed of rotating parts, 2) maximum diameter of tools, 3) mass (in kilograms) of the machine itself and/or of removable parts, 4) maximum working load, 5) necessity of wearing personal protective equipment, 6) guard adjustment data, and 7) frequency of inspection. <p>Information printed directly on the machine should be permanent and remain legible throughout the expected life of the machine.</p> <p>Signs or written warnings indicating only "Danger" shall not be used.</p> <p>Markings, signs and written warnings shall be readily understandable and unambiguous, especially as regards the part of the function(s) of the machine to which they are related. Readily understandable signs (pictograms) should be used in preference to written warnings.</p> 	<p>P</p>	
---------------------	--	----------	--

Clause	Requirement-Test	Result	Verdict
	<p>Signs and pictograms should only be used if they are understood in the culture in which the machinery is to be Used.</p> <p>Written warnings shall be drawn up in the language(s) of the country in which the machine will be used for the first time and, on request, in the language(s) understood by operators.</p> <p>NOTE In some countries the use of specific language(s) is covered by legal requirements.</p> <p>Markings shall comply with recognized standards (for example, ISO 2972 or ISO 7000, for pictograms, symbols and colours in particular).</p> <p>See IEC 60204-1 as regards marking of electrical equipment.</p> <p>See ISO 4413 and ISO 4414 for hydraulic and pneumatic equipment.</p>		
6.4.5	Accompanying documents (in particular — instruction handbook)		
6.4.5.1	Contents		
	<p>The instruction handbook or other written instructions (for example, on the packaging) shall contain, among others, the following:</p> <p>a) information relating to transport, handling and storage of the machine, such as</p> <ol style="list-style-type: none"> 1) storage conditions for the machine, 2) dimensions, mass value(s), position of the centre(s) of gravity, and 3) indications for handling (for example, drawings indicating application points for lifting equipment); <p>b) information relating to installation and commissioning of the machine, such as</p> <ol style="list-style-type: none"> 1) fixing/anchoring and dampening of noise and vibration requirements, 2) assembly and mounting conditions, 3) space needed for use and maintenance, 4) permissible environmental conditions (for example, temperature, moisture, vibration, electromagnetic radiation), 5) instructions for connecting the machine to power supply (particularly on protection against electrical overloading), 6) advice on waste removal/disposal, and 7) if necessary, recommendations related to protective measures which have to be implemented by the user — for example, additional safeguards (see Figure 2, Footnote d), safety distances, safety signs and signals; <p>c) information relating to the machine itself, such as</p> <ol style="list-style-type: none"> 1) detailed description of the machine, its fittings, guards and/or protective devices, 2) the comprehensive range of applications for which the machine is intended, including prohibited usages, if any, taking into account variations of the original machine if appropriate, 3) diagrams (especially schematic representation of safety functions), 4) data on noise and vibration generated by the machine, and on radiation, gases, vapours and dust emitted by it, with reference to the measuring methods (including measurement uncertainties) used, 5) technical documentation of electrical equipment (see IEC 60204), and 6) documents attesting that the machine complies with mandatory requirements; <p>d) information relating to the use of the machine, such as that related to or describing</p> <ol style="list-style-type: none"> 1) intended use, 2) manual controls (actuators), 3) setting and adjustment, 	P	

Clause	Requirement-Test	Result	Verdict
	<p>4) modes and means for stopping (especially emergency stop),</p> <p>5) risks which could not be eliminated by the protective measures implemented by the designer,</p> <p>6) particular risks which can be generated by certain applications, by the use of certain fittings, and about specific safeguards necessary for such applications,</p> <p>7) reasonably foreseeable misuse and prohibited applications,</p> <p>8) fault identification and location, for repair and for restarting after an intervention, and</p> <p>9) personal protective equipment needed to be used and the training that is required;</p> <p>e) information for maintenance, such as</p> <p>1) the nature and frequency of inspections for safety functions,</p> <p>2) specification of the spare parts to be used when these can affect the health and safety of operators,</p> <p>3) instructions relating to maintenance operations which require a definite technical knowledge or particular skills and hence need to be carried out exclusively by skilled persons (for example, maintenance staff, specialists),</p> <p>4) instructions relating to maintenance actions (replacement of parts, etc.) which do not require specific skills and hence may be carried out by users (for example, operators), and</p> <p>5) drawings and diagrams enabling maintenance personnel to carry out their task rationally (especially fault-finding tasks);</p> <p>f) information relating to dismantling, disabling and scrapping;</p> <p>g) information for emergency situations, such as</p> <p>1) the operating method to be followed in the event of accident or breakdown,</p> <p>2) the type of fire-fighting equipment to be used, and</p> <p>3) a warning of possible emission or leakage of hazardous substance(s) and, if possible, an indication of means for fighting their effects;</p> <p>h) maintenance instructions provided for skilled persons [item e) 3) above] and maintenance instructions provided for unskilled persons [item e) 4) above], that need to appear clearly separated from each other.</p>		
6.4.5.2	Production of instruction handbook		
	<p>The following applies to the production and presentation of the instruction handbook.</p> <p>a) The type font and size of print shall ensure the best possible legibility. Safety warnings and/or cautions should be emphasized by the use of colours, symbols and/or large print.</p> <p>b) The information for use shall be given in the language(s) of the country in which the machine will be used for the first time and in the original version. If more than one language is to be used, each should be readily distinguished from another, and efforts should be made to keep the translated text and relevant illustration together.</p> <p>NOTE In some countries the use of specific language(s) is covered by legal requirements.</p> <p>c) Whenever helpful to the understanding, text should be supported by illustrations. These illustrations should be supplemented with written details enabling, for example, manual controls (actuators) to be located and identified. They should not be separated from the accompanying text and should follow sequential operations.</p> <p>d) Consideration should be given to presenting information in tabular form where this will aid understanding. Tables should be adjacent to the relevant text.</p> <p>e) The use of colours should be considered, particularly in relation to components requiring quick identification.</p>	P	

Clause	Requirement-Test	Result	Verdict
--------	------------------	--------	---------

	<p>f) When information for use is lengthy, a table of contents and/or an index should be provided.</p> <p>g) Safety-relevant instructions which involve immediate action should be provided in a form readily available to the operator.</p>		
--	--	--	--

6.4.5.3 Drafting and editing information for use

6.4.5.3	<p>The following applies to the drafting and editing of information for use.</p> <p>a) Relationship to model: the information shall clearly relate to the specific model of machine and, if necessary, other appropriate identification (for example, by serial number).</p> <p>b) Communication principles: when information for use is being prepared, the communication process “see – think – use” should be followed in order to achieve the maximum effect and should follow sequential operations. The questions, “How?” and “Why?” should be anticipated and the answers provided.</p> <p>c) Information for use shall be as simple and as brief as possible, and should be expressed in consistent terms and units with a clear explanation of unusual technical terms.</p> <p>d) When it is foreseen that a machine will be put to non-professional use, the instructions should be written in a form that is readily understood by the non-professional user. If personal protective equipment is required for the safe use of the machine, clear advice should be given, for example, on the packaging as well as on the machine, so that this information is prominently displayed at the point of sale.</p> <p>e) Durability and availability of the documents: documents giving instructions for use should be produced in durable form (i.e. they should be able to survive frequent handling by the user). It can be useful to mark them “keep for future reference”. Where information for use is kept in electronic form (CD, DVD, tape, hard disk, etc.), information on safety-related issues that need immediate action shall always be backed up with a hard copy that is readily available.</p>	P	
---------	---	---	--

7 Documentation of risk assessment and risk reduction

	<p>The documentation shall demonstrate the procedure that has been followed and the results that have been achieved. This includes, when relevant, documentation of</p> <p>a) the machinery for which the risk assessment has been made (for example, specifications, limits, intended use);</p> <p>b) any relevant assumptions that have been made (loads, strengths, safety factors, etc.);</p> <p>c) the hazards and hazardous situations identified and the hazardous events considered in the risk assessment;</p> <p>d) the information on which risk assessment was based (see 5.2):</p> <p>1) the data used and the sources (accident histories, experience gained from risk reduction applied to similar machinery, etc.);</p> <p>2) the uncertainty associated with the data used and its impact on the risk assessment;</p> <p>e) the risk reduction objectives to be achieved by protective measures;</p> <p>f) the protective measures implemented to eliminate identified hazards or to reduce risk;</p> <p>g) residual risks associated with the machinery;</p> <p>h) the result of the risk assessment (see Figure 1);</p> <p>i) any forms completed during the risk assessment.</p> <p>Standards or other specifications used to select protective measures referred to in f) above should be referenced.</p> <p>NOTE No requirement is given in this International Standard to deliver the risk assessment documentation together with the machine. See ISO/TR 14121-2 for information on</p>	P	
--	---	---	--

Clause	Requirement-Test	Result	Verdict
--------	------------------	--------	---------

	documentation.		
--	----------------	--	--

EN 60204-1

4.1	General		
------------	----------------	--	--

	<p>This part of IEC 60204 is intended to apply to electrical equipment used with a wide variety of machines and with a group of machines working together in a co-coordinated manner.</p> <p>The risks associated with the hazards relevant to the electrical equipment shall be assessed as part of the overall requirements for risk assessment of the machine. This will determine the adequate risk reduction and the necessary protective measures for persons who can be exposed to those hazards, while still maintaining an acceptable level of performance of the machine and its equipment.</p>	P	
--	---	---	--

4.2 Selection of equipment

4.2.1	General		
--------------	----------------	--	--

	<p>Electrical components and devices shall:</p> <ul style="list-style-type: none"> —be suitable for their intended use; and —conform to relevant IEC standards where such exist; and —be applied in accordance with the supplier’s instructions risk assessment of the machine. 	P	
--	--	---	--

4.2.2	Electrical equipment in compliance with the EN 60439 series		
--------------	--	--	--

	<p>Depending upon the machine, its intended use and its electrical equipment, the designer may select parts of the electrical equipment of the machine that are in compliance with EN 60439-1 and, as necessary, other relevant parts of the EN 60439 series (see also Annex F).</p>	P	
--	--	---	--

4.3 Electrical supply

4.3.1	General		
--------------	----------------	--	--

	<p>The electrical equipment shall be designed to operate correctly with the conditions of the supply:</p> <ul style="list-style-type: none"> —as specified in 4.3.2 or 4.3.3, or —as otherwise specified by the user (see Annex B), or as specified by the supplier in the case of a special source of supply such as an on-board generator. 	P	
--	--	---	--

4.3.2	AC supplies		
--------------	--------------------	--	--

	<p>Voltage:</p> <p>Steady state voltage: 0,9 to 1,1 of nominal voltage.</p> <p>Frequency:</p> <p>0,99 to 1,01 of nominal frequency continuously;</p> <p>0,98 to 1,02 short time.</p> <p>Harmonics:</p> <p>Harmonic distortion not exceeding 10 % of the total r.m.s. voltage between live conductors for the sum of the 2nd through to the 5th harmonic. An additional 2 % of the total r.m.s. voltage between live conductors for the sum of the 6th through to the 30th harmonic is permissible.</p> <p>Voltage unbalance:</p> <p>Neither the voltage of the negative sequence component nor the voltage of the zero sequence components in three-phase supplies exceeding 2 % of the positive sequence component.</p> <p>Voltage interruption:</p> <p>Supply interrupted or at zero voltage for not more than 3 ms at any random time in the supply cycle with more than 1 s between successive interruptions.</p> <p>Voltage dips:</p>	P	<p>AC: 220V</p> <p>Sum_{2nd-5th harmonic} <= 10%</p> <p>Sum_{6nd-30th harmonic} <= 2%</p> <p>60Hz</p> <p>Voltage unbalance <= 2%</p> <p>Voltage interruption <= 3ms</p> <p>Rms* 0.707</p> <p>Voltage dips <= 20%</p>
--	--	---	---

Clause	Requirement-Test	Result	Verdict
	Voltage dips not exceeding 20 % of the peak voltage of the supply for more than one cycle with more than 1 s between successive dips.		
4.3.3	DC supplies		
	From batteries, Voltage 0,85 to 1,15 of nominal voltage 0,7 to 1,2 of nominal voltage in the case of battery-operated vehicles. Voltage interruption: Not exceeding 5 ms From converting equipment. Voltage: 0,9 to 1,1 of nominal voltage. Voltage interruption: Not exceeding 20 ms with more than 1 s between successive interruptions. Ripple (peak-to-peak): Not exceeding 0,15 of nominal voltage.	N	
4.3.4	Special supply systems		
	For special supply systems such as on-board generators, the limits given in 4.3.2 and 4.3.3 may be exceeded provided that the equipment is designed to operate correctly with those conditions.	P	
4.4 Physical environment and operating conditions			
4.4.1	General		
	The electrical equipment shall be suitable for the physical environment and operating conditions of its intended use. The requirements of 4.4.2 to 4.4.8 cover the physical environment and operating conditions of the majority of machines covered by this part of EN 60204. When special conditions apply or the limits specified are exceeded, an agreement between user and supplier (see 4.1) is recommended (see Annex B).	P	
4.4.3	Ambient air temperature		
	Electrical equipment shall be capable of operating correctly in the intended ambient air temperature. The minimum requirement for all electrical equipment is correct operation between air temperatures of +5 °C and +40 °C. For very hot environments (for example hot climates, steel mills, paper mills) and for cold environments, additional measures are recommended (see Annex B).	P	35%~85% Safety instruction
4.4.4	Humidity		
	The electrical equipment shall be capable of operating correctly when the relative humidity does not exceed 50 % at a maximum temperature of +40 °C. Higher relative humidities are permitted at lower temperatures (for example 90% at 20 °C). Harmful effects of occasional condensation shall be avoided by design of the equipment or where necessary, by additional measures (for example built-in heaters, air conditioners, drain holes).	P	Safety instruction
4.4.5	Altitude		
	Electrical equipment shall be capable of operating correctly at altitudes up to 1000 m above mean sea level.	P	up to 1000 m above m.s.l.
4.4.6	Contaminants		
	Electrical equipment shall be adequately protected against the ingress of solids and liquids The electrical equipment shall be adequately protected against contaminants (for example dust, acids, corrosive gases, salts) that can be present in the physical environment in which the electrical equipment is to be installed (see Annex B).	P	Safety instruction
4.4.7	Ionizing and non-ionizing radiation		

Standard: EN 60204-1:2006/AC: 2010, EN ISO 12100:2010

Clause	Requirement-Test	Result	Verdict
	When equipment is subject to radiation (for example microwave, ultraviolet, lasers, X-rays), additional measures shall be taken to avoid malfunctioning of the equipment and accelerated deterioration of the insulation. A special agreement is recommended between the supplier and the user (see Annex B).	P	Safety instruction
4.4.8	Vibration, shock, and bump		
	Undesirable effects of vibration, shock and bump (including those generated by the machine and its associated equipment and those created by the physical environment) shall be avoided by the selection of suitable equipment, by mounting it away from the machine, or by provision of anti-vibration mountings. A special agreement is recommended between the supplier and the user (see Annex B).	P	Safety instruction
4.5	Transportation and storage		
	Electrical equipment shall be designed to withstand, or suitable precautions shall be taken to protect against, the effects of transportation and storage at temperatures within a range of -25 °C to +55 °C and for short periods not exceeding 24 h at up to +70 °C. Suitable means shall be provided to prevent damage from humidity, vibration, and shock. A special agreement can be necessary between the supplier and the user (see Annex B).	P	Safety instruction
4.6	Provisions for handling		
	Heavy and bulky electrical equipment that has to be removed from the machine for transport or that is independent of the machine, shall be provided with suitable means for handling by cranes or similar equipment.	P	Safety instruction
4.7	Installation		
	Electrical equipment shall be installed in accordance with the electrical equipment supplier's Instructions.	P	Safety instruction
5 Incoming supply conductor terminations and devices for disconnecting and switching off			
5.1	Incoming supply conductor terminations		
	<p>It is recommended that, where practicable, the electrical equipment of a machine is connected to a single incoming supply. Where another supply is necessary for certain parts of the equipment (for example, electronic equipment that operates at a different voltage), that supply should be derived, as far as is practicable, from devices (for example, transformers, converters) forming part of the electrical equipment of the machine. For large complex machinery comprising a number of widely-spaced machines working together in a coordinated manner, there can be a need for more than one incoming supply depending upon the site supply arrangements (see 5.3.1)</p> <p>Unless a plug is provided with the machine for the connection to the supply (see 5.3.2 e), it is recommended that the supply conductors are terminated at the supply disconnecting device.</p> <p>Where a neutral conductor is used it shall be clearly indicated in the technical documentation of the machine, such as in the installation diagram and in the circuit diagram, and a separate insulated terminal, labeled N in accordance with 16.1, shall be provided for the neutral conductor (see also Annex B).</p> <p>There shall be no connection between the neutral conductor and the protective bonding circuit inside the electrical equipment nor shall a combined PEN terminal be provided.</p> <p>Exception: a connection may be made between the neutral terminal and the PE terminal at the point of the connection of the power supply to the machine for TN-C systems.</p> <p>All terminals for the incoming supply connection shall be clearly identified in accordance with IEC</p>	P	

Clause	Requirement-Test	Result	Verdict
	60445 and 16.1. For the identification of the external protective conductor terminal, see 5.2. See 17.8 for the provision of instructions for maintenance.		
5.2	Terminal for connection to the external protective earthing system		
	For each incoming supply, a terminal shall be provided in the vicinity of the associated phase conductor terminals for connection of the machine to the external protective earthing system or to the external protective conductor, depending upon the supply distribution system. The terminal shall be of such a size as to enable the connection of an external protective copper conductor with a cross-sectional area in accordance with Table 1.	P	Earth Resistance 2.5Ω, Connected with copper wire S=25mm ²
5.3 Supply disconnecting (isolating) device			
5.3.1	General		
	A supply disconnecting device shall be provided: —for each incoming source of supply to a machine(s); —for each on-board power supply. The supply disconnecting device shall disconnect (isolate) the electrical equipment of the machine from the supply when required (for example for work on the machine, including the electrical equipment). When two or more supply disconnecting devices are provided, protective interlocks for their correct operation shall also be provided in order to prevent a hazardous situation, including damage to the machine or to the work in progress.	P	A supply disconnecting device has been provided
5.3.2	Type		
	The supply disconnecting device shall be one of the following types: a) switch-disconnect or, with or without fuses, in accordance with IEC 60947-3, utilization category AC-23B or DC-23B; b) disconnect or, with or without fuses, in accordance with IEC 60947-3, that has an auxiliary contact that in all cases causes switching devices to break the load circuit before the opening of the main contacts of the disconnect; c) a circuit-breaker suitable for isolation in accordance with IEC 60947-2; d) any other switching device in accordance with an IEC product standard for that device and which meets the isolation requirements of IEC 60947-1 as well as a utilization category defined in the product standard as appropriate for on-load switching of motors or other inductive loads; e) a plug/socket combination for a flexible cable supply.	P	
5.3.3	Requirements		
	When the supply disconnecting device is one of the types specified in 5.3.2 a) to d) it shall fulfill all of the following requirements: —isolate the electrical equipment from the supply and have one OFF (isolated) and one ON position marked with "O" and "I" (symbols IEC 60417-5008 (DB:2002-10) and IEC 60417-5007 (DB:2002-10), see 10.2.2); —have a visible contact gap or a position indicator which cannot indicate OFF (isolated) until all contacts are actually open and the requirements for the isolating function have been satisfied; —have an external operating means (for example handle), (exception: power-operated switchgear need not be operable from outside the enclosure where there are other means to open it). Where the external operating means is not intended for emergency operations, it is	P	isolate the electrical equipment from the supply and have one OFF (isolated) and one ON position

Clause	Requirement-Test	Result	Verdict
	<p>recommended that it be colored BLACK or GREY (see 10.7.4 and 10.8.4);</p> <p>—be provided with a means permitting it to be locked in the OFF (isolated) position (for example by padlocks). When so locked, remote as well as local closing shall be prevented;</p> <p>—disconnect all live conductors of its power supply circuit. However, for TN supply systems, the neutral conductor may or may not be disconnected except in countries where disconnection of the neutral conductor (when used) is compulsory;</p> <p>—have a breaking capacity sufficient to interrupt the current of the largest motor when stalled together with the sum of the normal running currents of all other motors and/or loads. The calculated breaking capacity may be reduced by the use of a proven diversity factor.</p> <p>When the supply disconnecting device is a plug/socket combination, it shall fulfill the following requirements: have the switching capability, or be interlocked with a switching device that has a breaking capacity, sufficient to interrupt the current of the largest motor when stalled together with the sum of the normal running currents of all other motors and/or loads. The calculated breaking capacity may be reduced by the use of a proven diversity factor.</p> <p>When the interlocked switching device is electrically operated (for example a contactor) it</p> <p>—shall have an appropriate utilization category.</p> <p>Where the supply disconnecting device is a plug/socket combination, a switching device with an appropriate utilization category shall be provided for switching the machine on and off.</p> <p>This can be achieved by the use of the interlocked switching device described above.</p>		
5.3.4	Operating means		
	<p>The operating means (for example, a handle) of the supply disconnecting device shall be easily accessible and located between 0,6 m and 1,9 m above the servicing level. An upper limit of 1,7 m is recommended.</p>	P	1,7 m
5.3.5	Excepted circuits		
	<p>The following circuits need not be disconnected by the supply disconnecting device:</p> <p>—lighting circuits for lighting needed during maintenance or repair;</p> <p>—plug and socket outlets for the exclusive connection of repair or maintenance tools and equipment (for example hand drills, test equipment);</p> <p>—under voltage protection circuits that are only provided for automatic tripping in the event of supply failure;</p> <p>—circuits supplying equipment that should normally remain energized for correct operation (for example temperature controlled measuring devices, product (work in progress) heaters, program storage devices);</p> <p>—control circuits for interlocking.</p> <p>It is recommended, however, that such circuits be provided with their own disconnecting device.</p> <p>Where such a circuit is not disconnected by the supply disconnecting device:</p> <p>—permanent warning label(s) in accordance with 16.1 shall be appropriately placed in proximity to the supply disconnecting device;</p> <p>—a corresponding statement shall be included in the maintenance manual, and one or more of the following shall apply;</p> <p>—a permanent warning label in accordance with 16.1 is affixed in proximity to each excepted circuit, or</p>	P	

Clause	Requirement-Test	Result	Verdict
	<p>—the excepted circuit is separated from other circuits, or</p> <p>—the conductors are identified by colour taking into account the recommendation of 13.2.4.</p>		
5.4	Devices for switching off for prevention of unexpected start-up		
	<p>Devices for switching off for the prevention of unexpected start-up shall be provided (for example where, during maintenance, a start-up of the machine or part of the machine can create a hazard).</p> <p>Such devices shall be appropriate and convenient for the intended use, shall be suitably placed, and readily identifiable as to their function and purpose (for example by a durable marking in accordance with 16.1 where necessary).</p>	P	Two buttons have to be pressed at a same time less than 0.5S discrepancy.
5.5	Devices for disconnecting electrical equipment		
	<p>Devices shall be provided for disconnecting (isolating) electrical equipment to enable work to be carried out when it is de-energized and isolated. Such devices shall be:</p> <ul style="list-style-type: none"> —appropriate and convenient for the intended use; —suitably placed; —readily identifiable as to which part(s) or circuit(s) of the equipment is served (for example by durable marking in accordance with 16.1 where necessary). <p>Means shall be provided to prevent inadvertent and/or mistaken closure of these devices either at the controller or from other locations (see also 5.6).</p> <p>The supply disconnecting device (see 5.3) may, in some cases, fulfil that function.</p> <p>However where it is necessary to work on individual parts of the electrical equipment of a machine, or on one of a number of machines fed by a common conductor bar, conductor wire or inductive power supply system, a disconnecting device shall be provided for each part, or for each machine, requiring separate isolation.</p> <p>In addition to the supply disconnecting device, the following devices that fulfil the isolation function may be provided for this purpose:</p> <ul style="list-style-type: none"> —devices described in 5.3.2; —disconnectors, withdrawable fuse links and withdrawable links only if located in an electrical operating area (see 3.15) and relevant information is provided with the electrical equipment (see 17.2 b)9) and b)12)). 	P	
5.6	Protection against unauthorized, inadvertent and/or mistaken connection		
	<p>The devices described in 5.4 and 5.5 that are located outside an enclosed electrical operating area shall be equipped with means to secure them in the OFF position (disconnected state), (for example by provisions for padlocking, trapped key interlocking). When so secured, remote as well as local reconnection shall be prevented.</p> <p>Where a non-lockable disconnecting device (for example withdrawable fuse-links withdrawable links) other means of protection against reconnection (for example warning labels in accordance with 16.1) may be provided.</p> <p>However, when a plug/socket combination according to 5.3.2 e) is so positioned that it can be kept under the immediate supervision of the person carrying out the work, means for securing in the disconnected state need not be provided.</p>	P	Using system of safety for electro-sensitivity
6 Protection against electric shock			
6.1	General		
	<p>The electrical equipment shall provide protection of persons against electric shock from:</p> <ul style="list-style-type: none"> – direct contact (see 6.2 and 6.4); 	P	

Clause	Requirement-Test	Result	Verdict
	<p>– indirect contact (see 6.3 and 6.4).</p> <p>The measures for this protection given in 6.2, 6.3, and, for PELV, in 6.4, are a recommended selection from IEC 60364-4-41. Where those recommended measures are not practicable, for example due to the physical or operational conditions, other measures from IEC 60364-4-41 may be used.</p>		
6.2	Protection against direct contact		
6.2.1	General		
	<p>For each circuit or part of the electrical equipment, the measures of either 6.2.2 or 6.2.3 and where applicable, 6.2.4 shall be applied.</p> <p>Exception: where those measures are not appropriate, other measures for protection against direct contact (for example by using barriers, by placing out of reach, using obstacles, using construction or installation techniques that prevent access) as defined in IEC 60364-4-41 may be applied (see 6.2.5 and 6.2.6).</p> <p>When the equipment is located in places open to all persons, which can include children measures of either 6.2.2 with a minimum degree of protection against direct contact corresponding to IP4X or IPXXD (see IEC 60529), or 6.2.3 shall be applied.</p>	P	IP4X
6.2.2	Protection by enclosures		
	<p>Live parts shall be located inside enclosures that conform to the relevant requirements of Clauses 4, 11, and 14 and that provide protection against direct contact of at least IP2X or IPXXB (see IEC 60529).</p> <p>Where the top surfaces of the enclosure are readily accessible, the minimum degree of protection against direct contact provided by the top surfaces shall be IP4X or IPXXD Opening an enclosure (i.e. opening doors, lids, covers, and the like) shall be possible only under one of the following conditions:</p> <p>a:</p> <p>b:</p> <p>c:</p>	P	IP45
6.2.3	Protection by insulation of live parts		
	<p>Live parts protected by insulation shall be completely covered with insulation that can only be removed by destruction. Such insulation shall be capable of withstanding the mechanical, chemical, electrical, and thermal stresses to which it can be subjected under normal operating conditions.</p>	P	IP42
6.2.4	Protection against residual voltages		
	<p>Live parts having a residual voltage greater than 60 V after the supply has been disconnected shall be discharged to 60 V or less within a time period of 5 s after disconnection of the supply voltage provided that this rate of discharge does not interfere with the proper functioning of the equipment. Exempted from this requirement are components having a stored charge of 60 μC or less.</p> <p>Where this specified rate of discharge would interfere with the proper functioning of the equipment, a durable warning notice drawing attention to the hazard and stating the delay required before the enclosure may be opened shall be displayed at an easily visible location on or immediately adjacent to the enclosure containing the capacitances.</p> <p>In the case of plugs or similar devices, the withdrawal of which results in the exposure of conductors (for example pins), the discharge time shall not exceed 1 s, otherwise such</p>	P	IP12 IP22 IP22

Standard: EN 60204-1:2006/AC: 2010, EN ISO 12100:2010

Clause	Requirement-Test	Result	Verdict
	conductors shall be protected against direct contact to at least IP2X or IPXXB. If neither a discharge time of 1 s nor a protection of at least IP2X or IPXXB can be achieved (for example in the case of removable collectors on conductor wires, conductor bars, or slip-ring assemblies, see 12.7.4), additional switching devices or an appropriate warning device (for example a warning notice in accordance with 16.1) shall be applied.		
6.2.5	Protection by barriers		
	For protection by barriers, 412.2 of IEC 60364-4-41 shall apply.	P	
6.2.6	Protection by placing out of reach or protection by obstacles		
	For protection by placing out of reach, 412.4 of IEC 60364-4-41 shall apply. For protection by obstacles, 412.3 of IEC 60364-4-41 shall apply. For conductor wire systems or conductor bar systems with a degree of protection less than IP2X, see 12.7.1.	P	IP22
6.3 Protection against indirect contact			
6.3.1	General		
	Protection against indirect contact (3.29) is intended to prevent hazardous situations due to an insulation fault between live parts and exposed conductive parts. For each circuit or part of the electrical equipment, at least one of the measures in accordance with 6.3.2 to 6.3.3 shall be applied: – measures to prevent the occurrence of a touch voltage (6.3.2); or – automatic disconnection of the supply before the time of contact with a touch voltage can become hazardous (6.3.3).	P	
6.3.2 Prevention of the occurrence of a touch voltage			
6.3.2.1	General		
	Measures to prevent the occurrence of a touch voltage include the following: —provision of class II equipment or by equivalent insulation; —electrical separation.	P	
6.3.2.2	Protection by provision of class II equipment or by equivalent insulation		
	This measure is intended to prevent the occurrence of touch voltages on the accessible parts through a fault in the basic insulation. This protection is provided by one or more of the following: —class II electrical devices or apparatus (double insulation, reinforced insulation or by equivalent insulation in accordance with IEC 61140); —switchgear and control gear assemblies having total insulation in accordance with IEC 60439-1; —supplementary or reinforced insulation in accordance with 413.2 of IEC 60364-4-41.	P	
6.3.2.3	Protection by electrical separation		
	Electrical separation of an individual circuit is intended to prevent a touch voltage through contact with exposed conductive parts that can be energized by a fault in the basic insulation of the live parts of that circuit. For this type of protection, the requirements of 413.5 of IEC 60364-4-41 apply.	P	
6.3.3	Protection by automatic disconnection of supply		
	This measure consists of the interruption of one or more of the line conductors by the automatic operation of a protective device in case of a fault. This interruption shall occur within a sufficiently short time to limit the duration of a touch voltage to a time within which the touch voltage is not	P	

Clause	Requirement-Test	Result	Verdict
	hazardous. Interruption times are given in Annex A.		
6.4 Protection by the use of PELV			
6.4.1	General requirements		
	The use of PELV (Protective Extra-Low Voltage) is to protect persons against electric shock from indirect contact and limited area direct contact (see 8.2.5). PELV circuits shall satisfy all of the conditions.	P	
6.4.2	Sources for PELV		
	The source for PELV shall be one of the following: —a safety isolating transformer in accordance with IEC 61558-1 and IEC 61558-2-6; —a source of current providing a degree of safety equivalent to that of the safety isolating transformer (for example a motor generator with winding providing equivalent isolation); —an electrochemical source (for example a battery) or another source independent of a higher voltage circuit (for example a diesel-driven generator); —an electronic power supply conforming to appropriate standards specifying measures to be taken to ensure that, even in the case of an internal fault, the voltage at the outgoing terminals cannot exceed the values specified in 6.4.1.	P	
7 Protection of equipment			
7.1	General		
	This Clause details the measures to be taken to protect equipment against the effects of: —overcurrent arising from a short circuit; —overload and/or loss of cooling of motors; —abnormal temperature; —loss of or reduction in the supply voltage; —overspeed of machines/machine elements; —earth fault/residual current; —incorrect phase sequence; —overvoltage due to lightning and switching surges.	P	
7.2 Overcurrent protection			
7.2.1	General		
	Overcurrent protection shall be provided where the current in a machine circuit can exceed either the rating of any component or the current carrying capacity of the conductors whichever is the lesser value. The ratings or settings to be selected are detailed in 7.2.10.	P	
7.2.2	Supply conductors		
	Unless otherwise specified by the user, the supplier of the electrical equipment is not responsible for providing the overcurrent protective device for the supply conductors to the electrical equipment (see Annex B). The supplier of the electrical equipment shall state on the installation diagram the data necessary for selecting the overcurrent protective device (see 7.2.10 and 17.4).	P	
7.2.3	Power circuits		
	Devices for detection and interruption of overcurrent, selected in accordance with 7.2.10 shall be applied to each live conductor. The following conductors, as applicable, shall not be disconnected without disconnecting all associated live conductors:	P	

Clause	Requirement-Test	Result	Verdict
	<p>—the neutral conductor of a.c. power circuits;</p> <p>—the earthed conductor of d.c. power circuits;</p> <p>—d.c. power conductors bonded to exposed conductive parts of mobile machines.</p> <p>Where the cross-sectional area of the neutral conductor is at least equal to or equivalent to that of the phase conductors, it is not necessary to provide over current detection for the neutral conductor nor a disconnecting device for that conductor. For a neutral conductor with a cross-sectional area smaller than that of the associated phase conductors, the measures detailed in 524 of IEC 60364-5-52 shall apply.</p> <p>In IT systems, it is recommended that the neutral conductor is not used. However, where a neutral conductor is used, the measures detailed in 431.2.2 of IEC 60364-4-43 shall apply.</p>		
7.2.4	Control circuits		
	<p>Conductors of control circuits directly connected to the supply voltage and of circuits supplying control circuit transformers shall be protected against over current in accordance with 7.2.3.</p> <p>Conductors of control circuits supplied by a control circuit transformer or d.c. supply shall be protected against over current (see also 9.4.3.1):</p> <p>—in control circuits connected to the protective bonding circuit, by inserting an over current protective device into the switched conductor;</p> <p>—in control circuits not connected to the protective bonding circuit;</p> <p>—where the same cross sectional area conductors are used in all control circuits, by inserting an over current protective device into the switched conductor, and;</p> <p>—where different cross sectional areas conductors are used in different sub-circuits, by inserting an overcurrent protective device into both switched and common conductors of each sub-circuit.</p>	P	
7.2.5	Socket outlets and their associated conductors		
	<p>Overcurrent protection shall be provided for the circuits feeding the general purpose socket outlets intended primarily for supplying power to maintenance equipment. Overcurrent protective devices shall be provided in the unearthed live conductors of each circuit feeding such socket outlets.</p>	P	
7.2.6	Lighting circuits		
	<p>All unearthed conductors of circuits supplying lighting shall be protected against the effects of short circuits by the provision of over current devices separate from those protecting other circuits.</p>	P	
7.2.7	Transformers		
	<p>Transformers shall be protected against over current in accordance with the manufacturer's instructions. Such protection shall (see also 7.2.10):</p> <p>—avoid nuisance tripping due to transformer magnetizing inrush currents;</p> <p>—avoid a winding temperature rise in excess of the permitted value for the insulation class of transformer when it is subjected to the effects of a short circuit at its secondary terminals.</p> <p>The type and setting of the over current protective device should be in accordance with the recommendations of the transformer supplier.</p>	P	
7.2.8	Location of over current protective devices		
	<p>An over current protective device shall be located at the point where a reduction in the cross-sectional area of the conductors or another change reduces the current-carrying capacity of the conductors, except where all the following conditions are satisfied:</p> <p>– the current carrying capacity of the conductors is at least equal to that of the load;</p>	P	

Clause	Requirement-Test	Result	Verdict
	<p>– the part of the conductor between the point of reduction of current-carrying capacity and the position of the overcurrent protective device is no longer than 3 m;</p> <p>– the conductor is installed in such a manner as to reduce the possibility of a short-circuit, for example, protected by an enclosure or duct.</p>		
7.2.9	Overcurrent protective devices		
	<p>The rated short-circuit breaking capacity shall be at least equal to the prospective fault current at the point of installation. Where the short-circuit current to an over current protective device can include additional currents other than from the supply (for example from motors from power factor correction capacitors), those currents shall be taken into consideration.</p> <p>A lower breaking capacity is permitted where another protective device (for example the over current protective device for the supply conductors (see 7.2.2) having the necessary breaking capacity is installed on the supply side. In that case, the characteristics of the two devices shall be co-ordinated so that the let-through energy (I^2t) of the two devices in series does not exceed that which can be withstood without damage to the over current protective device on the load side and to the conductors protected by that device (see Annex A of IEC 60947-2).</p> <p>Where fuses are provided as over current protective devices, a type readily available in the country of use shall be selected, or arrangements shall be made for the supply of spare parts.</p>	P	Using fuses wire as protective device
7.2.10	Rating and setting of overcurrent protective devices		
	<p>The rated current of fuses or the setting current of other over current protective devices shall be selected as low as possible but adequate for the anticipated over currents (for example during starting of motors or energizing of transformers). When selecting those protective devices, consideration shall be given to the protection of switching devices against damage due to over currents (for example welding of the switching device contacts).</p> <p>The rated current or setting of an over current protective device is determined by the current carrying capacity of the conductors to be protected in accordance with 12.4, D.2 and the maximum allowable interrupting time t in accordance with Clause D.3, taking into account the needs of co-ordination with other electrical devices in the protected circuit.</p>	P	
7.3 Protection of motors against overheating			
7.3.1	General		
	<p>Protection of motors against overheating shall be provided for each motor rated at more than 0,5 kW.</p> <p>Exceptions:</p> <p>In applications where an automatic interruption of the motor operation is unacceptable (for example fire pumps), the means of detection shall give a warning signal to which the operator can respond.</p> <p>Protection of motors against overheating can be achieved by:</p> <ul style="list-style-type: none"> —overload protection (7.3.2), —over-temperature protection (7.3.3), or —current-limiting protection (7.3.4). <p>Automatic restarting of any motor after the operation of protection against overheating shall be prevented where this can cause a hazardous situation or damage to the machine or to the work in progress.</p>	P	
7.3.2	Overload protection		
	Where overload protection is provided, detection of overload(s) shall be provided in each live	P	

Clause	Requirement-Test	Result	Verdict
	<p>conductor except for the neutral conductor. However, where the motor overload detection is not used for cable overload protection (see also Clause D.2), the number of overload detection devices may be reduced at the request of the user (see also Annex B). For motors having single-phase or d.c. power supplies, detection in only one unearthed live conductor is permitted.</p> <p>Where overload protection is achieved by switching off, the switching device shall switch off all live conductors. The switching of the neutral conductor is not necessary for overload protection.</p> <p>Where motors with special duty ratings are required to start or to brake frequently (for example, motors for rapid traverse, locking, rapid reversal, sensitive drilling) it can be difficult to provide overload protection with a time constant comparable with that of the winding to be protected. Appropriate protective devices designed to accommodate special duty motors or over-temperature protection (see 7.3.3) can be necessary.</p> <p>For motors that cannot be overloaded (for example torque motors, motion drives that either are protected by mechanical overload protection devices or are adequately dimensioned), overload protection is not required.</p>		
7.3.3	Over-temperature protection		
	<p>The provision of motors with over-temperature protection (see IEC 60034-11) is recommended in situations where the cooling can be impaired (for example dusty environments). Depending upon the type of motor, protection under stalled rotor or loss of phase conditions is not always ensured by over-temperature protection, and additional protection should then be provided.</p> <p>Over-temperature protection is also recommended for motors that cannot be overloaded (for example torque motors, motion drives that are either protected by mechanical overload protection devices or are adequately dimensioned), where the possibility of over-temperature exists (for example due to reduced cooling).</p>	P	
7.3.4	Current limiting protection		
	<p>Where protection against the effects of overheating in three phase motors is achieved by current limitation, the number of current limitation devices may be reduced from 3 to 2 (see 7.3.2). For motors having single phase a.c or d.c. power supplies, current limitation in only one unearthed live conductor is permitted.</p>	P	
7.4	Abnormal temperature protection		
	<p>Resistance heating or other circuits that are capable of attaining or causing abnormal temperatures (for example, due to short-time rating or loss of cooling medium) and therefore can cause a hazardous situation shall be provided with suitable detection to initiate an appropriate control response.</p>	P	
7.5	Protection against supply interruption or voltage reduction and subsequent restoration		
	<p>Where a supply interruption or a voltage reduction can cause a hazardous situation, damage to the machine, or to the work in progress, under voltage protection shall be provided by, for example, switching off the machine at a predetermined voltage level.</p> <p>Where the operation of the machine can allow for an interruption or a reduction of the voltage for a short time period, delayed under voltage protection may be provided. The operation of the under voltage device shall not impair the operation of any stopping control of the machine.</p> <p>Upon restoration of the voltage or upon switching on the incoming supply, automatic or unexpected restarting of the machine shall be prevented where such a restart can cause a hazardous situation.</p> <p>Where only a part of the machine or of the group of machines working together in a coordinated</p>	P	

Clause	Requirement-Test	Result	Verdict
	manner is affected by the voltage reduction or supply interruption, the under voltage protection shall initiate appropriate control responses to ensure co-ordination.		
7.6	Motor overspeed protection		
	Overspeed protection shall be provided where overspeeding can occur and could possibly cause a hazardous situation taking into account measures in accordance with 9.3.2. Overspeed protection shall initiate appropriate control responses and shall prevent automatic restarting. The overspeed protection should operate in such a manner that the mechanical speed limit of the motor or its load is not exceeded.	P	
7.7	Earth fault/residual current protection		
	In addition to providing over current protection for automatic disconnection as described in 6.3, earth fault/residual current protection can be provided to reduce damage to equipment due to earth fault currents less than the detection level of the over current protection. The setting of the devices shall be as low as possible consistent with correct operation of the equipment.	P	Using copper wire connect to the earth system.
7.8	Phase sequence protection		
	Where an incorrect phase sequence of the supply voltage can cause a hazardous situation or damage to the machine, protection shall be provided.	P	L1 L2 L3
7.9	Protection against over voltages due to lightning and to switching surges		
	Protective devices can be provided to protect against the effects of overvoltage due to lightning or to switching surges. Where provided: —devices for the suppression of over voltages due to lightning shall be connected to the incoming terminals of the supply disconnecting device. —devices for the suppression of over voltages due to switching surges shall be connected across the terminals of all equipment requiring such protection.	P	
8 Equipment potential bonding			
8.1	General		
	This Clause provides requirements for both protective bonding and functional bonding.	P	
8.2 Protective bonding circuit			
8.2.1	General		
	The protective bonding circuit consists of: – PE terminal(s) (see 5.2); – the protective conductors in the equipment of the machine including sliding contacts where they are part of the circuit; – the exposed conductive parts and conductive structural parts of the electrical equipment; – those extraneous conductive parts which form the structure of the machine. All parts of the protective bonding circuit shall be so designed that they are capable of withstanding the highest thermal and mechanical stresses that can be caused by earth-fault currents that could flow in that part of the protective bonding circuit.	P	
8.2.2	Protective conductors		
	Protective conductors shall be identified in accordance with 13.2.2. Copper conductors are preferred. Where a conductor material other than copper is used, its	P	20 mm ²

Clause	Requirement-Test	Result	Verdict
	<p>electrical resistance per unit length shall not exceed that of the allowable copper conductor and such conductors shall be not less than 16 mm² in cross-sectional area.</p> <p>The cross-sectional area of protective conductors shall be determined in accordance with the requirements of:</p> <p>—543 of IEC 60364-5-54; or</p> <p>—7.4.3.1.7 of IEC 60439-1, as appropriate.</p> <p>This requirement is met in most cases where the relationship between the cross-sectional area of the phase conductors associated with that part of the equipment and the cross-sectional area of the associated protective conductor is in accordance with Table 1 (see 5.2) See also 8.2.8.</p>		
8.2.3	Continuity of the protective bonding circuit		
	<p>All exposed conductive parts shall be connected to the protective bonding circuit in accordance with 8.2.1.</p> <p>Exception: see 8.2.5.</p> <p>Where a part is removed for any reason (for example routine maintenance), the protective bonding circuit for the remaining parts shall not be interrupted.</p> <p>Connection and bonding points shall be so designed that their current-carrying capacity is not impaired by mechanical, chemical, or electrochemical influences. Where enclosures and conductors of aluminium or aluminium alloys are used, particular consideration should be given to the possibility of electrolytic corrosion.</p> <p>Metal ducts of flexible or rigid construction and metallic cable sheaths shall not be used as protective conductors. Nevertheless, such metal ducts and the metal sheathing of all connecting cables (for example cable armouring, lead sheath) shall be connected to the protective bonding circuit.</p> <p>Where the electrical equipment is mounted on lids, doors, or cover plates, continuity of the protective bonding circuit shall be ensured and a protective conductor (see 8.2.2) is recommended. Otherwise fastenings, hinges or sliding contacts designed to have a low resistance shall be used (see 18.2.2, Test 1).</p> <p>The continuity of the protective conductor in cables that are exposed to damage (for example flexible trailing cables) shall be ensured by appropriate measures (for example monitoring).</p> <p>For requirements for the continuity of the protective conductor using conductor wires, conductor bars and slip-ring assemblies, see 12.7.2.</p>	P	
8.2.4	Exclusion of switching devices from the protective bonding circuit		
	<p>The protective bonding circuit shall not incorporate a switching device or an overcurrent protective device (for example switch, fuse).</p> <p>No means of interruption of the protective bonding conductor shall be provided.</p> <p>Exception: links for test or measurement purposes that cannot be opened without the use of a tool and that are located in an enclosed electrical operating area.</p> <p>Where the continuity of the protective bonding circuit can be interrupted by means of removable current collectors or plug/socket combinations, the protective bonding circuit shall be interrupted by a first make last break contact. This also applies to removable or withdrawable plug-in units (see also 13.4.5).</p>	P	
8.2.5	Parts that need not be connected to the protective bonding circuit		
	<p>It is not necessary to connect exposed conductive parts to the protective bonding circuit where those parts are mounted so that they do not constitute a hazard because:</p>	P	

Standard: EN 60204-1:2006/AC: 2010, EN ISO 12100:2010

Clause	Requirement-Test	Result	Verdict
	<p>– they cannot be touched on large surfaces or grasped with the hand and they are small in size (less than approximately 50 mm × 50 mm); or</p> <p>– they are located so that either contact with live parts, or an insulation failure, is unlikely.</p> <p>This applies to small parts such as screws, rivets, and nameplates and to parts inside an enclosure, irrespective of their size (for example electromagnets of contactors or relays and mechanical parts of devices) (see also 410.3.3.5 of IEC 60364-4-41).</p>		
8.2.6	Protective conductor connecting points		
	<p>All protective conductors shall be terminated in accordance with 13.1.1. The protective conductor connecting points shall have no other function and are not intended, for example to attach or connect appliances or parts.</p> <p>Each protective conductor connecting point shall be marked or labelled as such using the symbol IEC 60417-5019 or with the letters PE, the graphical symbol being preferred, or by use of the bicolour combination GREEN-AND-YELLOW, or by any combination of these.</p>	P	
8.2.7	Mobile machines		
	<p>On mobile machines with on-board power supplies, the protective conductors, the conductive structural parts of the electrical equipment, and those extraneous conductive parts which form the structure of the machine shall all be connected to a protective bonding terminal to provide protection against electric shock. Where a mobile machine is also capable of being connected to an external incoming power supply, this protective bonding terminal shall be the connection point for the external protective conductor.</p>	P	
8.2.8	Additional protective bonding requirements for electrical equipment having earth leakage currents higher than 10mA a.c. or d.c.		
	<p>Where electrical equipment has an earth leakage current (for example adjustable speed electrical power drive systems and information technology equipment) that is greater than 10 mA a.c. or d.c. in any incoming supply, one or more of the following conditions for the associated protective bonding circuit shall be satisfied:</p> <p>a) the protective conductor shall have a cross-sectional area of at least 10 mm² Cu or 16 mm² Al, through its total run;</p> <p>b) where the protective conductor has a cross-sectional area of less than 10 mm² Cu or 16 mm² Al, a second protective conductor of at least the same cross-sectional area shall be provided up to a point where the protective conductor has a cross-sectional area not less than 10 mm² Cu or 16 mm² Al.</p> <p>c) automatic disconnection of the supply in case of loss of continuity of the protective conductor.</p> <p>To prevent difficulties associated with electromagnetic disturbances, the requirements of 4.4.2 also apply to the installation of duplicate protective conductors.</p> <p>In addition, a warning label shall be provided adjacent to the PE terminal, and where necessary on the nameplate of the electrical equipment. The information provided under 17.2 b)1) shall include information about the leakage current and the minimum cross-sectional area of the external protective conductor.</p>	P	12 mm ² Copper wire
8.3	Functional bonding		
	<p>Protection against maloperation as a result of insulation failures can be achieved by connecting to a common conductor in accordance with 9.4.3.1.</p> <p>For recommendations regarding functional bonding to avoid maloperation due to electromagnetic disturbances, see 4.4.2.</p>	P	
8.4	Measures to limit the effects of high leakage current		

Clause	Requirement-Test	Result	Verdict
	The effects of high leakage current can be restricted to the equipment having high leakage current by connection of that equipment to a dedicated supply transformer having separate windings. The protective bonding circuit shall be connected to exposed conductive parts of the equipment and, in addition, to the secondary winding of the transformer. The protective conductor(s) between the equipment and the secondary winding of the transformer shall comply with one or more of the arrangements described in 8.2.8.	P	< 10 µA
9 Control circuits and control functions			
9.1 Control circuits			
9.1.1	Control circuit supply		
	Where control circuits are supplied from an a.c. source, control transformers shall be used for supplying the control circuits. Such transformers shall have separate windings. Where several transformers are used, it is recommended that the windings of those transformers be connected in such a manner that the secondary voltages are in phase. Where d.c. control circuits derived from an a.c. supply are connected to the protective bonding circuit (see 8.2.1), they shall be supplied from a separate winding of the a.c. control circuit transformer or by another control circuit transformer. Transformers are not mandatory for machines with a single motor starter and/or a maximum of two control devices (for example interlock device, start/stop control station).	P	
9.1.2	Control circuit voltages		
	The nominal value of the control voltage shall be consistent with the correct operation of the control circuit. The nominal voltage shall not exceed 277 V when supplied from a transformer.	P	220V
9.1.3	Protection		
	Control circuits shall be provided with over current protection in accordance with 7.2.4 and 7.2.10.	P	
9.2 Control functions			
9.2.1	Start functions		
	Start functions shall operate by energizing the relevant circuit (see 9.2.5.2).	P	
9.2.2	Stop functions		
	There are three categories of stop functions as follows: —stop category 0: stopping by immediate removal of power to the machine actuators (i.e. an uncontrolled stop – see 3.56); —stop category 1: a controlled stop (see 3.11) with power available to the machine actuators to achieve the stop and then removal of power when the stop is achieved; —stop category 2: a controlled stop with power left available to the machine actuators.	P	Category 0
9.2.3	Operating modes		
	Each machine can have one or more operating modes determined by the type of machine and its application. When a hazardous situation can result from a mode selection unauthorized and/or inadvertent selection shall be prevented by suitable means (for example key operated switch, access code). Mode selection by itself shall not initiate machine operation. A separate actuation of the start control shall be required. For each specific operating mode, the relevant safety functions and/or protective measures shall be implemented. Indication of the selected operating mode shall be provided (for example the position of a mode	P	

Clause	Requirement-Test	Result	Verdict
	selector, the provision of an indicating light, a visual display indication).		
9.2.4	Suspension of safety functions and/or protective measures		
	Where it is necessary to suspend safety functions and/or protective measures (for example for setting or maintenance purposes), protection shall be ensured by: —disabling all other operating (control) modes	P	
9.2.5 Operation			
9.2.5.1	General		
	The necessary safety functions and/or protective measures (for example interlocks (see 9.3) shall be provided for safe operation. Measures shall be taken to prevent movement of the machine in an unintended or unexpected manner after any stopping of the machine (for example due to locked-off condition, power supply fault, battery replacement, lost signal condition with cableless control). Where a machine has more than one control station, measures shall be provided to ensure that initiation of commands from different control stations do not lead to a hazardous situation.	P	
9.2.5.2	Start		
	The start of an operation shall be possible only when all of the relevant safety functions and/or protective measures are in place and are operational except for conditions as described in 9.2.4. On those machines (for example mobile machines) where safety functions and/or protective measures cannot be applied for certain operations, manual control of such operations shall be by hold-to-run controls, together with enabling devices, as appropriate. Suitable interlocks shall be provided to secure correct sequential starting. In the case of machines requiring the use of more than one control station to initiate a start, each of these control stations shall have a separate manually actuated start control device. The conditions to initiate a start shall be: – all required conditions for machine operation shall be met, and – all start control devices shall be in the released (off) position, then – all start control devices shall be actuated concurrently (see 3.6).	P	
9.2.5.3	Stop		
	Stop category 0 and/or stop category 1 and/or stop category 2 stop functions shall be provided as indicated by the risk assessment and the functional requirements of the machine. Stop functions shall override related start functions (see 9.2.5.2). Where required, facilities to connect protective devices and interlocks shall be provided. If such a protective device or interlock causes a stop of the machine, it may be necessary for that condition to be signaled to the logic of the control system. The reset of the stop function shall not initiate any hazardous situation. Where more than one control station is provided, stop commands from any control station shall be effective when required by the risk assessment of the machine.	P	
9.2.5.4 Emergency operations (emergency stop, emergency switching off)			
9.2.5.4.1	General		
	The emergency stop and the emergency switching off functions of the emergency operations listed in Annex E, both of which are, in this part of IEC 60204, initiated by a single human action. Once active operation of an emergency stop (see 10.7) or emergency switching off (see 10.8) actuator has ceased following a command, the effect of this command shall be sustained until it is reset. This reset shall be possible only by a manual action at that location where the command	P	

Clause	Requirement-Test	Result	Verdict
	<p>has been initiated. The reset of the command shall not restart the machinery but only permit restarting.</p> <p>It shall not be possible to restart the machinery until all emergency stop commands have been reset. It shall not be possible to reenergize the machinery until all emergency switching off commands have been reset.</p>		
9.2.5.4.2	Emergency stop		
	<p>Given in ISO 13850.</p> <p>The emergency stop shall function either as a stop category 0 or as a stop category 1 (see 9.2.2). The choice of the stop category of the emergency stop depends on the results of a risk assessment of the machine.</p> <p>In addition to the requirements for stop (see 9.2.5.3), the emergency stop function has the following requirements:</p> <ul style="list-style-type: none"> —it shall override all other functions and operations in all modes; —power to the machine actuators that can cause a hazardous situation(s) shall be either removed immediately (stop category 0) or shall be controlled in such a way to stop the hazardous motion as quickly as possible (stop category 1) without creating other hazards; —reset shall not initiate a restart. 	P	Category 0
9.2.5.4.3	Emergency switching off		
	<p>The functional aspects of emergency switching off are given in 536.4 of IEC 60364-5-53.</p> <p>Emergency switching off should be provided where:</p> <ul style="list-style-type: none"> —protection against direct contact (for example with conductor wires, conductor bars, slip ring assemblies, control gear in electrical operating areas) is achieved only by placing out of reach or by obstacles (see 6.2.6); or —there is the possibility of other hazards or damage caused by electricity. <p>Emergency switching off is accomplished by switching off the relevant incoming supply by electromechanical switching devices, effecting a stop category 0 of machine actuators connected to this incoming supply. When a machine cannot tolerate this stop category 0 stop, it may be necessary to provide other measures, for example protection against direct contact so that emergency switching off is not necessary.</p>	P	Category 0
9.2.5.5	Monitoring of command actions		
	<p>Movement or action of a machine or part of a machine that can result in a hazardous situation shall be monitored by providing, for example, over travel limiters, motor overspeed detection, mechanical overload detection or anti-collision devices.</p>	P	
9.2.6 Other control functions			
9.2.6.1	Hold-to-run controls		
	<p>Hold-to-run controls shall require continuous actuation of the control device(s) to achieve operation.</p>	P	
9.2.6.2	Two-hand control		
	<p>Three types of two-hand control are defined in ISO 13851, the selection of which is determined by the risk assessment. These shall have the following features:</p> <p>Type I: this type requires:</p> <ul style="list-style-type: none"> – the provision of two control devices and their concurrent actuation by both hands; – continuous concurrent actuation during the hazardous situation; 	N	

Clause	Requirement-Test	Result	Verdict
	<p>– machine operation shall cease upon the release of either one or both of the control devices when hazardous situations are still present.</p> <p>A Type I two-hand control device is not considered to be suitable for the initiation of hazardous operation.</p> <p>Type II: a type I control requiring the release of both control devices before machine operation can be reinitiated.</p> <p>Type III: a type II control requiring concurrent actuation of the control devices as follows:</p> <p>– it shall be necessary to actuate the control devices within a certain time limit of each other, not exceeding 0,5 s;</p> <p>– where this time limit is exceeded, both control devices shall be released before machine operation can be initiated.</p>		
9.2.6.3	Enabling control		
	<p>Enabling control (see also 10.9) is a manually activated control function interlock that:</p> <p>a) when activated allows a machine operation to be initiated by a separate start control and b) when de-activated</p> <p>—initiates a stop function in accordance with 9.2.5.3, and</p> <p>—prevents initiation of machine operation.</p> <p>Enabling control shall be so arranged as to minimize the possibility of defeating, for example by requiring the de-activation of the enabling control device before machine operation may be reinitiated. It should not be possible to defeat the enabling function by simple means.</p>	P	
9.2.6.4	Combined start and stop controls		
	<p>Push-buttons and similar control devices that, when operated, alternately initiate and stop motion shall only be provided for functions which cannot result in a hazardous situation.</p>	P	
9.2.7 Cableless control			
9.2.7.1	General		
	<p>This sub clause deals with the functional requirements of control systems employing cableless (for example radio, infra-red) techniques for transmitting commands and signals between a machine control system and operator control station(s).</p> <p>Means shall be provided to readily remove or disconnect the power supply of the operator control station (see also 9.2.7.3).</p> <p>Means (for example key operated switch, access code) shall be provided, as necessary, to prevent unauthorized use of the operator control station.</p> <p>Each operator control station shall carry an unambiguous indication of which machine(s) is (are) intended to be controlled by that operator control station.</p>	P	
9.2.7.2	Control limitation		
	<p>Measures shall be taken to ensure that control commands:</p> <p>—affect only the intended machine;</p> <p>—affect only the intended functions.</p> <p>Measures shall be taken to prevent the machine from responding to signals other than those from the intended operator control station(s).</p> <p>Where necessary, means shall be provided so that the machine can only be controlled from operator control stations in one or more predetermined zones or locations.</p>	P	
9.2.7.3	Stop		
	<p>Cableless control stations shall include a separate and clearly identifiable means to initiate the</p>	P	

Clause	Requirement-Test	Result	Verdict
	<p>stop function of the machine or of all the operations that can cause a hazardous situation. The actuating means to initiate this stop function shall not be marked or labelled as an emergency stop device (see10.7).</p> <p>A machine which is equipped with cableless control shall have a means of automatically initiating the stopping of the machine and of preventing a potentially hazardous operation, in the following situations:</p> <ul style="list-style-type: none"> – when a stop signal is received; – when a fault is detected in the cableless control system; – when a valid signal (which includes a signal that communication is established and maintained) has not been detected within a specified period of time (see Annex B), except when a machine is executing a pre-programmed task taking it outside the range of the cableless control where no hazardous situation can occur. 		
9.2.7.4	Use of more than one operator control station		
	<p>Where a machine has more than one operator control station, including one or more cableless control stations, measures shall be provided to ensure that only one of the control stations can be enabled at a given time. An indication of which operator control station is in control of the machine shall be provided at suitable locations as determined by the risk assessment of the machine.</p> <p>Exception: a stop command from any one of the control stations shall be effective when required by the risk assessment of the machine.</p>	P	
9.2.7.5	Battery-powered operator control stations		
	<p>A variation in the battery voltage shall not cause a hazardous situation. If one or more potentially hazardous motions are controlled using a battery-powered cableless operator control station, a clear warning shall be given to the operator when a variation in battery voltage exceeds specified limits. Under those circumstances, the cableless operator control station shall remain functional long enough for the operator to put the machine into a nonhazardous situation.</p>	P	
9.3 Protective interlocks			
9.3.1	Reclosing or resetting of an interlocking safeguard		
	<p>The reclosing or resetting of an interlocking safeguard shall not initiate hazardous machine operation.</p>	P	
9.3.2	Exceeding operating limits		
	<p>Where an operating limits (for example speed, pressure, position) can be exceeded leading to a hazardous situation, means shall be provided to detect when a predetermined limit(s) is exceeded and initiate an appropriate control action.</p>	P	
9.3.3	Operation of auxiliary functions		
	<p>The correct operation of auxiliary functions shall be checked by appropriate devices (for example pressure sensors).</p> <p>Where the non-operation of a motor or device for an auxiliary function (for example lubrication, supply of coolant, swarf removal) can cause a hazardous situation, or cause damage to the machine or to the work in progress, appropriate interlocking shall be provided.</p>	P	
9.3.4	Interlocks between different operations and for contrary motions		
	<p>All contactors, relays, and other control devices that control elements of the machine and that can cause a hazardous situation when actuated at the same time (for example those which initiate contrary motion), shall be interlocked against incorrect operation.</p>	P	

Clause	Requirement-Test	Result	Verdict
	<p>Reversing contactors (for example those controlling the direction of rotation of a motor) shall be interlocked in such a way that in normal service no short circuit can occur when switching.</p> <p>Where, for safety or for continuous operation, certain functions on the machine are required to be interrelated, proper co-ordination shall be ensured by suitable interlocks. For a group of machines working together in a co-ordinated manner and having more than one controller, provision shall be made to co-ordinate the operations of the controllers as necessary.</p> <p>Where a failure of a mechanical brake actuator can result in the brake being applied when the associated machine actuator is energized and a hazardous situation can result, interlocks shall be provided to switch off the machine actuator.</p>		
9.3.5	Reverse current braking		
	<p>Where braking of a motor is accomplished by current reversal, measures shall be provided to prevent the motor starting in the opposite direction at the end of braking where that reversal can cause a hazardous situation or damage to the machine or to the work in progress. For this purpose, a device operating exclusively as a function of time is not permitted.</p> <p>Control circuits shall be so arranged that rotation of a motor shaft, for example manually shall not result in a hazardous situation.</p>	P	
9.4 Control functions in the event of failure			
9.4.1	General requirements		
	<p>Where failures or disturbances in the electrical equipment can cause a hazardous situation or damage to the machine or to the work in progress, appropriate measures shall be taken to minimize the probability of the occurrence of such failures or disturbances. The required measures and the extent to which they are implemented, either individually or in combination, depend on the level of risk associated with the respective application (see 4.1).</p>	P	
9.4.2 Measures to minimize risk in the event of failure			
9.4.2.1	Use of proven circuit techniques and components		
	<p>These measures include but are not limited to:</p> <ul style="list-style-type: none"> —bonding of control circuits to the protective bonding circuit for functional purposes (see 9.4.3.1 and Figure 2); —connection of control devices in accordance with 9.4.3.1; —stopping by de-energizing (see 9.2.2); —the switching of all control circuit conductors to the device being controlled (see 9.4.3.1); —switching devices having direct opening action (see IEC 60947-5-1); —circuit design to reduce the possibility of failures causing undesirable operations. 	P	
9.4.2.2	Provisions of partial or complete redundancy		
	<p>By providing partial or complete redundancy, it is possible to minimize the probability that one single failure in the electrical circuit can result in a hazardous situation. Redundancy can be effective in normal operation (on-line redundancy) or designed as special circuits that take over the protective function (off-line redundancy) only where the operating function fails.</p> <p>Where off-line redundancy which is not active during normal operation is provided, suitable measures shall be taken to ensure that those control circuits are available when required.</p>	P	
9.4.2.3	Provision of diversity		
	<p>The use of control circuits having different principles of operation, or using different types of components or devices can reduce the probability of hazards resulting from faults and/or failures.</p> <p>Examples include:</p>	P	Directly using diversity

Clause	Requirement-Test	Result	Verdict
	<p>—the combination of normally open and normally closed contacts operated by interlocking guards;</p> <p>—the use of different types of control circuit components in the circuit;</p> <p>—the combination of electromechanical and electronic equipment in redundant configurations.</p> <p>The combination of electrical and non-electrical systems (for example mechanical, hydraulic, pneumatic) may perform the redundant function and provide the diversity.</p>		
9.4.2.4	Provision for functional tests		
	Functional tests may be carried out automatically by the control system, or manually by inspection or tests at start-up and at predetermined intervals or a combination as appropriate (see also 17.2 and 18.6).	P	
9.4.3 Protection against maloperation due to earth faults, voltage interruptions and loss of circuit continuity			
9.4.3.1	Earth faults		
	<p>Earth faults on any control circuit shall not cause unintentional starting, potentially hazardous motions, or prevent stopping of the machine.</p> <p>Methods to meet these requirements include but are not limited to the following:</p> <p>Method a)</p> <p>Method b)</p> <p>Method c)</p>	P	Method a
9.4.3.2	Voltage interruptions		
	<p>The requirements detailed in 7.5 shall apply.</p> <p>Where the control system uses a memory device(s), proper functioning in the event of power failure shall be ensured (for example by using a non-volatile memory) to prevent any loss of memory that can result in a hazardous situation.</p>	P	
9.4.3.3	Loss of circuit continuity		
	Where the loss of continuity of safety-related control circuits depending upon sliding contacts can result in a hazardous situation, appropriate measures shall be taken (for example by duplication of the sliding contacts).	P	
10 Operator interface and machine-mounted control devices			
10.1 General			
10.1.1	General device requirements		
	<p>This Clause contains requirements for devices mounted outside or partially outside control enclosures.</p> <p>As far as is practicable, those devices shall be selected, mounted, and identified or coded in accordance with relevant parts of IEC 61310.</p> <p>The possibility of inadvertent operation shall be minimized by, for example, positioning of devices, suitable design, provision of additional protective measures. Particular consideration shall be given to the selection, arrangement, programming and use of operator input devices such as touchscreens, keypads and keyboards, for the control of hazardous machine operations. See IEC 60447.</p>	P	
10.1.2	Location and mounting		
	<p>As far as is practicable, machine-mounted control devices shall be:</p> <p>—readily accessible for service and maintenance;</p> <p>—mounted in such a manner as to minimize the possibility of damage from activities such as</p>	P	0,8M

Clause	Requirement-Test	Result	Verdict
	<p>material handling.</p> <p>The actuators of hand-operated control devices shall be selected and installed so that:</p> <ul style="list-style-type: none"> —they are not less than 0,6 m above the servicing level and are within easy reach of the normal working position of the operator; —the operator is not placed in a hazardous situation when operating them. <p>The actuators of foot-operated control devices shall be selected and installed so that:</p> <ul style="list-style-type: none"> —they are within easy reach of the normal working position of the operator; —the operator is not placed in a hazardous situation when operating them. 		
10.1.3	Protection		
	<p>The degree of protection (see IEC 60529) together with other appropriate measures shall afford protection against:</p> <ul style="list-style-type: none"> —the effects of aggressive liquids, vapours, or gases found in the physical environment or used on the machine; —the ingress of contaminants (for example swarf, dust, particulate matter). <p>In addition, the operator interface control devices shall have a minimum degree of protection against direct contact of IPXXD (see IEC 60529).</p>	P	
10.1.4	Position sensors		
	<p>Position sensors (for example position switches, proximity switches) shall be so arranged that they will not be damaged in the event of over travel.</p> <p>Position sensors in circuits with safety-related control functions shall have direct opening action (see IEC 60947-5-1) or shall provide similar reliability (see 9.4.2).</p>	P	
10.1.5	Portable and pendant control stations		
	<p>Portable and pendant operator control stations and their control devices shall be so selected and arranged as to minimize the possibility of inadvertent machine operations caused by shocks and vibrations (for example if the operator control station is dropped or strikes an obstruction) (see also 4.4.8).</p>	P	
10.2 Push-buttons			
10.2.1	Colors		
	<p>Push-button actuators shall be colour-coded in accordance with Table 2 (see also 9.2 and Annex B).</p> <p>The colours for START/ON actuators should be WHITE, GREY, BLACK or GREEN with a preference for WHITE. RED shall not be used.</p> <p>The colour RED shall be used for emergency stop and emergency switching off actuators.</p> <p>The colours for STOP/OFF actuators should be BLACK, GREY, or WHITE with a preference for BLACK. GREEN shall not be used. RED is permitted, but it is recommended that RED is not used near an emergency operation device.</p> <p>WHITE, GREY, or BLACK are the preferred colours for push-button actuators that alternately act as START/ON and STOP/OFF push-buttons. The colours RED, YELLOW, or GREEN shall not be used (see also 9.2.6).</p> <p>WHITE, GREY, or BLACK are the preferred colours for push-button actuators that cause operation while they are actuated and cease the operation when they are released (for example hold-to-run). The colours RED, YELLOW, or GREEN shall not be used.</p> <p>Reset push-buttons shall be BLUE, WHITE, GREY, or BLACK. Where they also act as a STOP/OFF button, the colours WHITE, GREY, or BLACK are preferred with the main preference</p>	P	<p>Red: emergency stop</p> <p>Yellow:</p> <p>Green: start</p> <p>White: no use</p> <p>Black: stop</p>

Clause	Requirement-Test	Result	Verdict
	<p>being for BLACK. GREEN shall not be used.</p> <p>Where the same colour WHITE, GREY, or BLACK is used for various functions (for example WHITE for START/ON and for STOP/OFF actuators) a supplementary means of coding (for example shape, position, symbol) shall be used for the identification of push-button actuators.</p>		
10.2.2	Markings		
	<p>In addition to the functional identification as described in 16.3, it is recommended that pushbuttons be marked, near to or preferably directly on the actuators, with the symbols given in Table 3.</p>	P	
10.3 Indicator lights and displays			
10.3.1	General		
	<p>Indicator lights and displays serve to give the following types of information:</p> <p>—indication: to attract the operator's attention or to indicate that a certain task should be performed. The colors RED, YELLOW, BLUE, and GREEN are normally used in this mode; for flashing indicator lights and displays, see 10.3.3.</p> <p>—confirmation: to confirm a command, or a condition, or to confirm the termination of a change or transition period. The colors BLUE and WHITE are normally used in this mode and GREEN may be used in some cases.</p> <p>Indicator lights and displays shall be selected and installed in such a manner as to be visible from the normal position of the operator.</p> <p>Indicator light circuits used for warning lights shall be fitted with facilities to check the operability of these lights.</p>	P	<p>Red light: emergency Green: normal</p>
10.3.2	Colors		
	<p>Unless otherwise agreed between the supplier and the user (see Annex B), indicator lights shall be colour-coded with respect to the condition (status) of the machine in accordance with Table 4. Indicating towers on machines should have the applicable colors in the following order from the top down; RED, YELLOW, BLUE, GREEN and WHITE.</p>	P	
10.3.3	Flashing lights and displays		
	<p>For further distinction or information and especially to give additional emphasis, flashing lights and displays can be provided for the following purposes:</p> <ul style="list-style-type: none"> – to attract attention; – to request immediate action; – to indicate a discrepancy between the command and actual state; – to indicate a change in process (flashing during transition). <p>It is recommended that higher frequency flashing lights or display be used for higher priority information (see IEC 60073 for recommended flashing rates and pulse/pause ratios).</p> <p>Where flashing lights or displays are used to provide higher priority information, audible warning devices should also be provided.</p>	P	
10.4	Illuminated push-buttons		
	<p>Illuminated push-button actuators shall be colour-coded in accordance with Tables 2 and 4. Where there is difficulty in assigning an appropriate colour, WHITE shall be used. The colour RED for the emergency stop actuator shall not depend on the illumination of its light.</p>	P	
10.5	Rotary control devices		
	<p>Devices having a rotational member, such as potentiometers and selector switches, shall have means of prevention of rotation of the stationary member.</p>	P	

Clause	Requirement-Test	Result	Verdict
	Friction alone shall not be considered sufficient.		
10.6	Start devices		
	Actuators used to initiate a start function or the movement of machine elements (for example slides, spindles, carriers) shall be constructed and mounted so as to minimize inadvertent operation. However, mushroom-type actuators may be used for two-hand control (see also ISO 13851).	P	
10.7 Emergency stop devices			
10.7.1	Location of emergency stop devices		
	Devices for emergency stop shall be readily accessible. Emergency stop devices shall be located at each operator control station and at other locations where the initiation of an emergency stop can be required (exception: see 9.2.7.3). There can be circumstances where confusion can occur between active and inactive emergency stop devices caused by disabling the operator control station. In such cases means (for example, information for use) shall be provided to minimize confusion.	P	In front of the operating table
10.7.2	Types of emergency stop device		
	The types of device for emergency stop include: – a push-button operated switch with a palm or mushroom head type; – a pull-cord operated switch; – a pedal-operated switch without a mechanical guard. The devices shall have direct opening operation (see IEC 60947-5-1, Annex K).	P	push-button back in manual operation
10.7.3	Color of actuators		
	Actuators of emergency stop devices shall be colored RED. If a background exists immediately around the actuator, then this background shall be colored YELLOW. See also ISO 13850.	P	Red in a background of yellow
10.7.4	Local operation of the supply disconnecting device to effect emergency stop		
	The supply disconnecting device may be locally operated to serve the function of emergency stop when: —it is readily accessible to the operator; and —it is of the type described in 5.3.2 a), b), c), or d). When also intended for such use, the supply disconnecting device shall meet the colour requirements of 10.7.3.	P	
10.8 Emergency switching off devices			
10.8.1	Location of emergency switching off devices		
	Emergency switching off devices shall be located as necessary for the given application. Normally, those devices will be located separate from operator control stations. Where it is necessary to provide a control station with an emergency stop device and an emergency switching off device, means shall be provided to avoid confusion between these devices.	P	Push-Button
10.8.2	Types of emergency switching off device		
	The types of device for emergency switching off include: —a push-button operated switch with a palm or mushroom head type of actuator; —a pull-cord operated switch. The devices shall have direct opening action (see IEC 60947-5-1, Annex K). The push-button operated switch may be in a break-glass enclosure.	P	back in manual operation
10.8.3	Color of actuators		

Clause	Requirement-Test	Result	Verdict
	Actuators of emergency switching off devices shall be coloured RED. If a background exists immediately around the actuator, then this background shall be coloured YELLOW. Where confusion can occur between emergency stop and emergency switching off devices, means shall be provided to minimise confusion.	P	Red in a background of yellow
10.8.4	Local operation of the supply disconnecting device to effect emergency switching off		
	Where the supply disconnecting device is to be locally operated for emergency switching off, it shall be readily accessible and should meet the color requirements of 10.8.3.	P	
10.9	Enabling control device		
	When an enabling control device is provided as a part of a system, it shall signal the enabling control to allow operation when actuated in one position only. In any other position, operation shall be stopped or prevented. Enabling control devices shall be selected and arranged so as to minimize the possibility of defeating. Enabling control devices shall be selected that have the following features: —designed in accordance with ergonomic principles; —for a two-position type: —position 1: off-function of the switch (actuator is not operated); —position 2: enabling function (actuator is operated). —for a three-position type: —position 1: off-function of the switch (actuator is not operated); —position 2: enabling function (actuator is operated in its mid position); —position 3: off-function (actuator is operated past its mid position); —when returning from position 3 to position 2, the enabling function is not activated.	P	Obvious to operator
11 Control gear: location, mounting, and enclosures			
11.1	General requirements		
	All control gear shall be located and mounted so as to facilitate: —its accessibility and maintenance; —its protection against the external influences or conditions under which it is intended to operate; —operation and maintenance of the machine and its associated equipment.	P	
11.2 Location and mounting			
11.2.1	Accessibility and maintenance		
	All items of control gear shall be placed and oriented so that they can be identified without moving them or the wiring. For items that require checking for correct operation or that are liable to need replacement, those actions should be possible without dismantling other equipment or parts of the machine (except opening doors or removing covers, barriers or obstacles). Terminals not part of control gear components or devices shall also conform to these requirements. All control gear shall be mounted so as to facilitate its operation and maintenance from the front. Where a special tool is necessary to adjust, maintain, or remove a device, such a tool shall be supplied. Where access is required for regular maintenance or adjustment, the relevant devices shall be located between 0,4 m and 2,0 m above the servicing level. It is recommended that terminals be at least 0,2 m above the servicing level and be so placed that conductors and cables can be easily connected to them. No devices except devices for operating, indicating, measuring, and cooling shall be mounted on doors or on normally removable access covers of	P	Input/output indicator

Clause	Requirement-Test	Result	Verdict
	<p>enclosures. Where control devices are connected through plug-in arrangements, their association shall be made clear by type (shape), marking or reference designation, singly or in combination (see 13.4.5).</p> <p>Plug-in devices that are handled during normal operation shall be provided with no interchangeable features where the lack of such a facility can result in malfunctioning.</p> <p>Plug/socket combinations that are handled during normal operation shall be located and mounted so as to provide unobstructed access.</p> <p>Test points for connection of test equipment, where provided, shall be:</p> <ul style="list-style-type: none"> —mounted so as to provide unobstructed access; —clearly identified to correspond with the documentation (see 17.3); —adequately insulated; —Sufficiently spaced. 		
11.2.2	Physical separation or grouping		
	<p>Non-electrical parts and devices, not directly associated with the electrical equipment, shall not be located within enclosures containing control gear.</p> <p>Devices such as solenoid valves should be separated from the other electrical equipment (for example in a separate compartment). Control devices mounted in the same location and connected to the supply voltage, or to both supply and control voltages, shall be grouped separately from those connected only to the control voltages.</p> <p>Terminals shall be separated into groups for:</p> <ul style="list-style-type: none"> —power circuits; —associated control circuits; —other control circuits, fed from external sources (for example for interlocking). <p>The groups may be mounted adjacently, provided that each group can be readily identified (for example by markings, by use of different sizes, by use of barriers or by colors).</p> <p>When arranging the location of devices (including interconnections), the clearances and creep age distances specified for them by the supplier shall be maintained, taking into account the external influences or conditions of the physical environment.</p>	P	
11.2.3	Heating effects		
	Heat generating components (for example heat sinks, power resistors) shall be so located that the temperature of each component in the vicinity remains within the permitted limit.	P	
11.3	Degrees of protection		
	<p>The protection of control gear against ingress of solid foreign objects and of liquids shall be adequate taking into account the external influences under which the machine is intended to operate (i.e. the location and the physical environmental conditions) and shall be sufficient against dust, coolants, and swarf.</p> <p>Enclosures of control gear shall provide a degree of protection of at least IP22 (see IEC 60529).</p> <p>Exceptions:</p> <ul style="list-style-type: none"> a) Where an electrical operating area is used as a protective enclosure for an appropriate degree of protection against the ingress of solid bodies and liquids. b) Where removable collectors on conductor wire or conductor bar systems are used and IP22 is not achieved, but the measures of 6.2.5 are applied. 	P	Degrees of protection: IP45
11.4 Enclosures, doors and openings		P	
12 Conductors and cables			

Standard: EN 60204-1:2006/AC: 2010, EN ISO 12100:2010

Clause	Requirement-Test	Result	Verdict
12.1	General requirements		
	Conductors and cables shall be selected so as to be suitable for the operating conditions (for example voltage, current, protection against electric shock, grouping of cables) and external influences (for example ambient temperature, presence of water or corrosive substances mechanical stresses (including stresses during installation), fire hazards) that can exist.	P	
12.2	Conductors		
	In general, conductors shall be of copper. Where aluminum conductors are used, the cross-sectional area shall be at least 16 mm ² . To ensure adequate mechanical strength, the cross-sectional area of conductors should not be less than as shown in Table 5. However, conductors with smaller cross-sectional areas or other constructions than shown in Table 5 may be used in equipment provided adequate mechanical strength is achieved by other means and proper functioning is not impaired.	P	20mm ²
12.3	Insulation		
	The types of insulation include (but are not limited to): —polyvinyl chloride (PVC); —rubber, natural and synthetic; —silicone rubber (SiR); —mineral; —cross-linked polyethylene (XLPE); —ethylene propylene compound (EPR). Where the insulation of conductors and cables (for example PVC) can constitute hazards due to the propagation of a fire or the emission of toxic or corrosive fumes, guidance from the cable supplier should be sought. It is important to give special attention to the integrity of a circuit having a safety-related function. The insulation of cables and conductors used, shall be suitable for a test voltage: —not less than 2 000 V a.c. for a duration of 5 min for operation at voltages higher than 50 V a.c. or 120 V d.c, or —not less than 500 V a.c. for a duration of 5 min for PELV circuits (see IEC 60364-4-41 class III equipment). The mechanical strength and thickness of the insulation shall be such that the insulation cannot be damaged in operation or during laying, especially for cables pulled into ducts.	P	Protection degree of electrical operation box: IP54 1000V ac for 5min
12.4	Current-carrying capacity in normal service		
	The current-carrying capacity depends on several factors, for example insulation material number of conductors in a cable, design (sheath), methods of installation, grouping and ambient temperature. One typical example of the current-carrying capacities for PVC insulated wiring between enclosures and individual items of equipment under steady-state conditions is given in Table 6.	P	Protection degree of electrical operation box: IP54
12.5	Conductor and cable voltage drop		
	The voltage drop from the point of supply to the load shall not exceed 5 % of the nominal voltage under normal operating conditions. In order to conform to this requirement, it can be necessary to use conductors having a larger cross-sectional area than that derived from Table 6.	P	
12.6 Flexible cables			
12.6.1	General		
	Flexible cables shall have Class 5 or Class 6 conductors.	P	Class 5

Clause	Requirement-Test	Result	Verdict
12.6.2	Mechanical rating		
	<p>The cable handling system of the machine shall be so designed to keep the tensile stress of the conductors as low as is practicable during machine operations. Where copper conductors are used, the tensile stress applied to the conductors shall not exceed 15 N/mm² of the copper cross-sectional area.</p> <p>Where the demands of the application exceed the tensile stress limit of 15 N/mm², cables with special construction features should be used and the allowed maximal tensile stress should be agreed with the cable manufacturer.</p> <p>The maximum stress applied to the conductors of flexible cables with material other than copper shall be within the cable manufacturer's specification.</p>	P	Flexible cables: CE certificate provided. 2000V/5min
12.6.3	Current-carrying capacity of cables wound on drums		
	<p>Cables to be wound on drums shall be selected with conductors having a cross-sectional area such that, when fully wound on the drum and carrying the normal service load, the maximum allowable conductor temperature is not exceeded.</p> <p>For cables of circular cross-sectional area installed on drums, the maximum current-carrying capacity in free air should be derated in accordance with Table 7 (see also Clause 44 of IEC 60621-3).</p>	P	
12.7 Conductor wires, conductor bars and slip-ring assemblies			
12.7.1	Protection against direct contact		
	<p>Conductor wires, conductor bars and slip-ring assemblies shall be installed or enclosed in such a way that, during normal access to the machine, protection against direct contact is achieved by the application of one of the following protective measures:</p> <ul style="list-style-type: none"> – protection by partial insulation of live parts, or where this is not practicable; – protection by enclosures or barriers of at least IP2X (see 412.2 of IEC 60364-4-41). <p>Horizontal top surfaces of barriers or enclosures that are readily accessible shall provide a degree of protection of at least IP4X (see 412.2.2 of IEC 60364-4-41).</p> <p>Where the required degree of protection is not achieved, protection by placing live parts out of reach in combination with emergency switching off in accordance with 9.2.5.4.3 shall be applied.</p> <p>Conductor wires and conductor bars shall be so placed and/or protected as to:</p> <ul style="list-style-type: none"> – prevent contact, especially for unprotected conductor wires and conductor bars, with conductive items such as the cords of pull-cord switches, strain-relief devices and drive chains; – prevent damage from a swinging load. 	P	
12.7.2	Protective conductor circuit		
	<p>Where conductor wires, conductor bars and slip-ring assemblies are installed as part of the protective bonding circuit, they shall not carry current in normal operation. Therefore, the protective conductor (PE) and the neutral conductor (N) shall each use a separate conductor wire, conductor bar or slip-ring. The continuity of the protective conductor circuit using sliding contacts shall be ensured by taking appropriate measures (for example, duplication of the current collector continuity monitoring).</p>	P	
12.7.3	Protective conductor current collectors		
	<p>Protective conductor current collectors shall have a shape or construction so that they are not interchangeable with the other current collectors. Such current collectors shall be of the sliding contact type.</p>	P	
12.7.4	Removable current collectors with a disconnecter function		

Standard: EN 60204-1:2006/AC: 2010, EN ISO 12100:2010

Clause	Requirement-Test	Result	Verdict
	Removable current collectors having a disconnecter function shall be so designed that the protective conductor circuit is interrupted only after the live conductors have been disconnected, and the continuity of the protective conductor circuit is re-established before any live conductor is reconnected (see also 8.2.4).	P	
12.7.5	Clearances in air		
	Clearances between the respective conductors and between adjacent systems, of conductor wires, conductor bars, slip-ring assemblies and their current collectors shall be suitable for at least a rated impulse voltage of an overvoltage category III in accordance with IEC 60664-1.	P	
12.7.6	Creepage distances		
	<p>Creepage distances between the respective conductors, between adjacent systems of conductor wires, conductor bars and slip-ring assemblies, and their current collectors shall be suitable for operation in the intended environment, for example open air (IEC 60664-1), inside buildings, protected by enclosures.</p> <p>In abnormally dusty, moist or corrosive environments, the following creepage distance requirements apply:</p> <ul style="list-style-type: none"> – unprotected conductor wires, conductor bars, and slip-ring assemblies shall be equipped with insulators with a minimum creepage distance of 60 mm; – enclosed conductor wires, insulated multipole conductor bars and insulated individual conductor bars shall have a minimum creepage distance of 30 mm. <p>The manufacturer's recommendations shall be followed regarding special measures to prevent a gradual reduction in the insulation values due to unfavourable ambient conditions (for example deposits of conductive dust, chemical attack).</p>	P	
12.7.7	Conductor system sectioning		
	Where conductor wires or conductor bars are arranged so that they can be divided into isolated sections, suitable design measures shall be employed to prevent the energization of adjacent sections by the current collectors themselves.	P	
12.7.8	Construction and installation of conductor wire, conductor bar systems and slip-ring assemblies		
	<p>Conductor wires, conductor bars and slip-ring assemblies in power circuits shall be grouped separately from those in control circuits.</p> <p>Conductor wires, conductor bars and slip-ring assemblies shall be capable of withstanding without damage, the mechanical forces and thermal effects of short-circuit currents.</p> <p>Removable covers for conductor wire and conductor bar systems laid underground or under floor shall be so designed that they cannot be opened by one person without the aid of a tool.</p> <p>Where conductor bars are installed in a common metal enclosure, the individual sections of the enclosure shall be bonded together and connected to a protective bonding conductor at several points depending upon their length.</p> <p>Metal covers of conductor bars laid underground or under floor shall also be bonded together and connected to a protective bonding conductor.</p> <p>The protective bonding circuit shall include the covers or cover plates of metal enclosures or under floor ducts. Where metal hinges form a part of the bonding circuit, their continuity shall be verified (see Clause 18).</p> <p>Underground and under floor conductor bar ducts shall have drainage facilities.</p>	P	
13 Wiring practices			
13.1 Connections and routing			

Standard: EN 60204-1:2006/AC: 2010, EN ISO 12100:2010

Clause	Requirement-Test	Result	Verdict
--------	------------------	--------	---------

13.1.1	General requirements		
	All connections, especially those of the protective bonding circuit, shall be secured against accidental loosening.	P	
13.1.2	Conductor and cable runs		
	<p>Conductors and cables shall be run from terminal to terminal without splices or joints.</p> <p>Connections using plug/socket combinations with suitable protection against accidental disconnection are not considered to be joints for the purpose of this Sub clause.</p> <p>Exception: Where it is impracticable to provide terminals in a junction box (for example on mobile machines, on machines having long flexible cables; cable connections exceeding a length which is not practical to be supplied by the cable manufacturer on one cable drum; repair of cable due to mechanical stresses during installation and operation), splices or joints may be used.</p> <p>Where it is necessary to connect and disconnect cables and cable assemblies, a sufficient extra length shall be provided for that purpose.</p> <p>The terminations of cables shall be adequately supported to prevent mechanical stresses at the terminations of the conductors.</p> <p>Wherever practicable, the protective conductor shall be placed close to the associated live conductors in order to decrease the impedance of the loop.</p>	P	
13.1.3	Conductors of different circuits		
	Conductors of different circuits may be laid side by side, may occupy the same duct (for example conduit, cable trunking system), or may be in the same multiconductor cable provided that the arrangement does not impair the proper functioning of the respective circuits. Where those circuits operate at different voltages, the conductors shall be separated by suitable barriers or shall be insulated for the highest voltage to which any conductor within the same duct can be subjected, for example line to line voltage for unearthed systems and phase to earth voltage for earthed systems.	P	
13.1.4	Connection between pick-up and pick-up converter of an inductive power supply system		
	<p>The cable between the pick-up and the pick-up converter as specified by the manufacturer of the inductive power supply shall be:</p> <ul style="list-style-type: none"> —as short as practicable; —adequately protected against mechanical damage. 	P	
13.2 Identification of conductors			
13.2.1	General requirements		
	<p>Each conductor shall be identifiable at each termination in accordance with the technical documentation (see Clause 17).</p> <p>It is recommended (for example to facilitate maintenance) that conductors be identified by number, alphanumeric, color (either solid or with one or more stripes), or a combination of color and numbers or alphanumeric. When numbers are used, they shall be Arabic; letters shall be Roman (either upper or lower case).</p>	P	
13.2.2	Identification of the protective conductor		
	<p>The protective conductor shall be readily distinguishable by shape, location, marking, or color.</p> <p>When identification is by color alone, the bicolor combination GREEN-AND-YELLOW shall be used throughout the length of the conductor. This colour identification is strictly reserved for the protective conductor.</p> <p>For insulated conductors, the bicolor combination GREEN-AND-YELLOW shall be such that on</p>	P	

Clause	Requirement-Test	Result	Verdict
	<p>any 15 mm length, one of the colors covers at least 30 % and not more than 70 % of the surface of the conductor, the other color covering the remainder of the surface.</p> <p>Where the protective conductor can be easily identified by its shape, position, or construction (for example a braided conductor, uninsulated stranded conductor), or where the insulated conductor is not readily accessible, color coding throughout its length is not necessary but the ends or accessible locations shall be clearly identified by the graphical symbol IEC 60417-5019 (DB: 2002-10) or by the bicolor combination GREEN-AND-YELLOW.</p>		
13.2.3	Identification of the neutral conductor		
	<p>Where a circuit includes a neutral conductor that is identified by color alone, the color used for this conductor shall be BLUE. In order to avoid confusion with other colors, it is recommended that an unsaturated blue be used, called here "light blue" (see 3.2.2 of IEC 60446). Where the selected color is the sole identification of the neutral conductor, that color shall not be used for identifying any other conductor where confusion is possible.</p> <p>Where identification by color is used, bare conductors used as neutral conductors shall be either colored by a stripe, 15 mm to 100 mm wide in each compartment or unit and at each accessible location, or colored throughout their length.</p>	P	
13.2.4	Identification by color		
	<p>Where color-coding is used for identification of conductors (other than the protective conductor (see 13.2.2) and the neutral conductor (see 13.2.3)), the following colors may be used:</p> <p>BLACK, BROWN, RED, ORANGE, YELLOW, GREEN, BLUE (including LIGHT BLUE), VIOLET, GREY, WHITE, PINK, TURQUOISE.</p>	P	
13.3	Wiring inside enclosures		
	<p>Conductors inside enclosures shall be supported where necessary to keep them in place.</p> <p>Non-metallic ducts shall be permitted only when they are made with a flame-retardant insulating material (see the IEC 60332 series).</p> <p>It is recommended that electrical equipment mounted inside enclosures be designed and constructed in such a way as to permit modification of the wiring from the front of the enclosure (see also 11.2.1). Where that is not practicable and control devices are connected from the rear of the enclosure, access doors or swing out panels shall be provided.</p>	P	
13.4 Wiring outside enclosures			
13.4.1	General requirements		
	<p>The means of introduction of cables or ducts with their individual glands, bushings, etc, into an enclosure shall ensure that the degree of protection is not reduced (see 11.3).</p>	P	
13.4.2	External ducts		
	<p>Conductors and their connections external to the electrical equipment enclosure(s) shall be enclosed in suitable ducts (i.e. conduit or cable trunking systems) as described in 13.5 except for suitably protected cables that may be installed without ducts and with or without the use of open cable trays or cable support means. Where devices such as position switches or proximity switches are supplied with a dedicated cable, their cable need not be enclosed in a duct when the cable is suitable for the purpose, sufficiently short, and so located or protected, that the risk of damage is minimized.</p> <p>Fittings used with ducts or multiconductor cable shall be suitable for the physical environment.</p>	P	
13.4.3	Connection to moving elements of the machine		
	<p>Connections to frequently moving parts shall be made using conductors in accordance with 12.2</p>	P	

Clause	Requirement-Test	Result	Verdict
	and 12.6. Flexible cable and flexible conduit shall be so installed as to avoid excessive flexing and straining, particularly at the fittings.		
13.4.4	Interconnection of devices on the machine		
	Where several machine-mounted switching devices (for example position sensors, pushbuttons) are connected in series or in parallel, it is recommended that the connections between those devices be made through terminals forming intermediate test points. Such terminals shall be conveniently placed, adequately protected, and shown on the relevant diagrams.	P	
13.4.5	Plug/socket combinations		
	Where plug/socket combinations are provided, they shall fulfill one or more of the following requirements as applicable: Exception: The following requirements do not apply to components or devices inside an enclosure, terminated by fixed plug/socket combinations (no flexible cable), or components connected to a bus system by a plug/socket combination. a)/b)/c)/d)/e)/f)/g)/ h)/i)/j)/k) Exception: The requirements of item k) do not apply to control functions using high frequency signals on the power supply.	P	
13.4.6	Dismantling for shipment		
	Where it is necessary that wiring be disconnected for shipment, terminals or plug/socket combinations shall be provided at the sectional points. Such terminals shall be suitably enclosed and plug/socket combinations shall be protected from the physical environment during transportation and storage.	P	
13.4.7	Additional conductors		
	Consideration should be given to providing additional conductors for maintenance or repair. When spare conductors are provided, they shall be connected to spare terminals or isolated in such a manner as to prevent contact with live parts.	P	
13.5 Ducts, connection boxes and other boxes			
13.5.1	General requirements		
	Ducts shall provide a degree of protection suitable for the application (see IEC 60529). All sharp edges, flash, burrs, rough surfaces, or threads with which the insulation of the conductors can come in contact shall be removed from ducts and fittings. Where necessary, additional protection consisting of a flame-retardant, oil-resistant insulating material shall be provided to protect conductor insulation. Drain holes of 6 mm diameter are permitted in cable trunking systems, connection boxes, and other boxes used for wiring purposes that can be subject to accumulations of oil or moisture.	P	
13.5.2	Percentage fill of ducts		
	Consideration of the percentage fill of ducts should be based on the straightness and length of the duct and the flexibility of the conductors. It is recommended that the dimensions and arrangement of the ducts be such as to facilitate the insertion of the conductors and cables.	P	
13.5.3	Rigid metal conduit and fittings		
	Rigid metal conduit and fittings shall be of galvanized steel or of a corrosion-resistant material suitable for the conditions. The use of dissimilar metals in contact that can cause galvanic action should be avoided. Conduits shall be securely held in place and supported at each end, Fittings shall be compatible with the conduit and appropriate for the application.	P	

Standard: EN 60204-1:2006/AC: 2010, EN ISO 12100:2010

Clause	Requirement-Test	Result	Verdict
	<p>Fittings shall be threaded unless structural difficulties prevent assembly.</p> <p>Where threadless fittings are used, the conduit shall be securely fastened to the equipment.</p> <p>Conduit bends shall be made in such a manner that the conduit shall not be damaged and the internal diameter of the conduit shall not be effectively reduced.</p>		
13.5.4	Flexible metal conduit and fittings		
	<p>A flexible metal conduit shall consist of a flexible metal tubing or woven wire armour. It shall be suitable for the expected physical environment.</p> <p>Fittings shall be compatible with the conduit and appropriate for the application.</p>	P	
13.5.5	Flexible non-metallic conduit and fittings		
	<p>Flexible non-metallic conduit shall be resistant to kinking and shall have physical characteristics similar to those of the sheath of multiconductor cables.</p> <p>The conduit shall be suitable for use in the expected physical environment.</p> <p>Fittings shall be compatible with the conduit and appropriate for the application.</p>	P	
13.5.6	Cable trunking systems		
	<p>Cable trunking systems external to enclosures shall be rigidly supported and clear of all moving or contaminating portions of the machine.</p> <p>Covers shall be shaped to overlap the sides; gaskets shall be permitted. Covers shall be attached to cable trunking systems by suitable means. On horizontal cable trunking systems, the cover shall not be on the bottom unless specifically designed for such installation.</p> <p>Where the cable trunking system is furnished in sections, the joints between sections shall fit tightly but need not be gasketed.</p> <p>The only openings permitted shall be those required for wiring or for drainage. Cable trunking systems shall not have opened but unused knockouts.</p>	P	
13.5.7	Machine compartments and cable trunking systems		
	<p>The use of compartments or cable trunking systems within the column or base of a machine to enclose conductors is permitted provided the compartments or cable trunking systems are isolated from coolant or oil reservoirs and are entirely enclosed. Conductors run in enclosed compartments and cable trunking systems shall be so secured and arranged that they are not subject to damage.</p>	P	
13.5.8	Connection boxes and other boxes		
	<p>Connection boxes and other boxes used for wiring purposes shall be accessible for maintenance. Those boxes shall provide protection against the ingress of solid bodies and liquids, taking into account the external influences under which the machine is intended to operate (see 11.3).</p> <p>Those boxes shall not have opened but unused knockouts nor any other openings and shall be so constructed as to exclude materials such as dust, flying, oil, and coolant.</p>	P	IP33
13.5.9	Motor connection boxes		
	<p>Motor connection boxes shall enclose only connections to the motor and motor-mounted devices (for example brakes, temperature sensors plugging switches, tachometer generators).</p>	P	IP54
14 Electric motors and associated equipment			
14.1	General requirements		
	<p>Electric motors should conform to the relevant parts of IEC 60034 series.</p> <p>The protection requirements for motors and associated equipment are given in 7.2 for over current protection, in 7.3 for overload protection, and in 7.6 for overspeed protection.</p> <p>As many controllers do not switch off the supply to a motor when it is at rest, care shall be taken</p>	P	

Clause	Requirement-Test	Result	Verdict
	to ensure compliance with the requirements of 5.3, 5.4, 5.5, 7.5, 7.6 and 9.4. Motor control equipment shall be located and mounted in accordance with Clause 11.		
14.2	Motor enclosures		
	It is recommended that motor enclosures be chosen from those included in IEC 60034-5. The degree of protection shall be at least IP23 (see IEC 60529) for all motors. More stringent requirements can be needed depending on the application and the physical environment (see 4.4). Motors incorporated as an integral part of the machine shall be so mounted that they are adequately protected from mechanical damage.	P	Protection degree: IP54
14.3	Motor dimensions		
	As far as is practicable, the dimensions of motors shall conform to those given in the IEC 60072 series.	P	
14.4	Motor mounting and compartments		
	<p>Each motor and its associated couplings, belts, pulleys, or chains, shall be so mounted that they are adequately protected and are easily accessible for inspection, maintenance, adjustment and alignment, lubrication, and replacement. The motor mounting arrangement shall be such that all motor hold-down means can be removed and all terminal boxes are accessible.</p> <p>Motors shall be so mounted that proper cooling is ensured and the temperature rise remains within the limits of the insulation class (see IEC 60034-1).</p> <p>Where practicable, motor compartments should be clean and dry, and when required, shall be ventilated directly to the exterior of the machine. The vents shall be such that ingress of swarf, dust, or water spray is at an acceptable level.</p> <p>There shall be no opening between the motor compartment and any other compartment that does not meet the motor compartment requirements. Where a conduit or pipe is run into the motor compartment from another compartment not meeting the motor compartment requirements, any clearance around the conduit or pipe shall be sealed.</p>	P	
14.5	Criteria for motor selection		
	<p>The characteristics of motors and associated equipment shall be selected in accordance with the anticipated service and physical environmental conditions (see 4.4). In this respect, the points that shall be considered include:</p> <ul style="list-style-type: none"> – type of motor; – type of duty cycle (see IEC 60034-1); – fixed speed or variable speed operation, (and the consequent variable influence of the ventilation); – mechanical vibration; – type of motor control; – influence of the harmonic spectrum of the voltage and/or current feeding the motor (particularly when it is supplied from a static convertor) on the temperature rise; – method of starting and the possible influence of the inrush current on the operation of other users of the same power supply, taking also into account possible special considerations stipulated by the supply authority; – variation of counter-torque load with time and speed; – influence of loads with large inertia; – influence of constant torque or constant power operation; – possible need of inductive reactors between motor and converter. 	P	

Clause	Requirement-Test	Result	Verdict
14.6	Protective devices for mechanical brakes		
	Operation of the overload and over current protective devices for mechanical brake actuators shall initiate the simultaneous de-energization (release) of the associated machine actuators.	P	
15 Accessories and lighting			
15.1	Accessories		
	Where the machine or its associated equipment is provided with socket-outlets that are intended to be used for accessory equipment (for example hand-held power tools, test equipment), the following apply: —the socket-outlets should conform to IEC 60309-1. Where that is not practicable, they should be clearly marked with the voltage and current ratings; —the continuity of the protective bonding circuit to the socket-outlet shall be ensured except where protection is provided by PELV; —all unearthed conductors connected to the socket-outlet shall be protected against over current and, when required, against overload in accordance with 7.2 and 7.3 separately from the protection of other circuits; —where the power supply to the socket-outlet is not disconnected by the supply disconnecting device for the machine or the section of the machine, the requirements of 5.3.5 apply.	P	
15.2 Local lighting of the machine and equipment			
15.2.1	General Connections to the protective		
	The ON/OFF switch shall not be incorporated in the lampholder or in the flexible connecting cords. Stroboscopic effects from lights shall be avoided by the selection of appropriate luminaries. Where fixed lighting is provided in an enclosure, electromagnetic compatibility should be taken into account using the principles outlined in 4.4.2.	P	
15.2.2	Supply		
	The nominal voltage of the local lighting circuit shall not exceed 250 V between conductors. A voltage not exceeding 50 V between conductors is recommended.	P	
15.2.3	Protection		
	Local lighting circuits shall be protected in accordance with 7.2.6.	P	
15.2.4	Fittings		
	Adjustable lighting fittings shall be suitable for the physical environment. The lamp holders shall be: —in accordance with the relevant IEC standard; —constructed with an insulating material protecting the lamp cap so as to prevent unintentional contact. Reflectors shall be supported by a bracket and not by the lamp holder. Exception: where fixed lighting is out of reach of operators during normal operation, the provisions of this Sub clause do not apply.	P	
16 Marking, warning signs and reference designations			
16.1	General		
	Warning signs, nameplates, markings, and identification plates shall be of sufficient durability to withstand the physical environment involved.	P	
16.2 Warning signs			
16.2.1	Electric shock hazard		

Standard: EN 60204-1:2006/AC: 2010, EN ISO 12100:2010

Clause	Requirement-Test	Result	Verdict
	<p>Enclosures that do not otherwise clearly show that they contain electrical equipment that can give rise to a risk of electric shock shall be marked with the graphical symbol IEC 60417-5036(DB: 2002-10).</p> <p>The warning sign shall be plainly visible on the enclosure door or cover.</p> <p>The warning sign may be omitted (see also 6.2.2 b)) for:</p> <ul style="list-style-type: none"> —an enclosure equipped with a supply disconnecting device; —an operator-machine interface or control station; —a single device with its own enclosure (for example position sensor). 	P	
16.2.2	Hot surfaces hazard		
	<p>Where the risk assessment shows the need to warn against the possibility of hazardous surface temperatures of the electrical equipment, the graphical symbol IEC 60417-5041 (DB: 2002-10) shall be used.</p>	P	
16.3	Functional identification		
	<p>Control devices, visual indicators, and displays (particularly those related to safety) shall be clearly and durably marked with regard to their functions either on or adjacent to the item.</p> <p>Such markings may be as agreed between the user and the supplier of the equipment (see Annex B). Preference should be given to the use of standard symbols given in IEC 60417- DB: 2002 and ISO 7000.</p>	P	
16.4	Marking of equipment		
	<p>Equipment (for example control gear assemblies) shall be legibly and durably marked in a way that is plainly visible after the equipment is installed. A nameplate giving the following information shall be attached to the enclosure adjacent to each incoming supply:</p> <ul style="list-style-type: none"> —name or trade mark of supplier; —certification mark, when required; —serial number, where applicable; —rated voltage, number of phases and frequency (if a.c.), and full-load current for each supply; —short-circuit rating of the equipment; —main document number (see IEC 62023). <p>The full-load current shown on the nameplate shall be not less than the running currents for all motors and other equipment that can be in operation at the same time under normal conditions.</p> <p>Where only a single motor controller is used, that information may instead be provided on the machine nameplate where it is plainly visible.</p>	P	
16.5	Reference designations		
	<p>All enclosures, assemblies, control devices, and components shall be plainly identified with the same reference designation as shown in the technical documentation.</p>	P	
17 Technical documentation			
17.1	General		
	<p>The information necessary for installation, operation, and maintenance of the electrical equipment of a machine shall be supplied in the appropriate forms, for example, drawings, diagrams, charts, tables, instructions. The information shall be in an agreed language (see also Annex B). The information provided may vary with the complexity of the electrical equipment. For very simple equipment, the relevant information may be contained in one document, provided that the document shows all the devices of the electrical equipment and enables the connections to the supply network to be made.</p>	P	

Clause	Requirement-Test	Result	Verdict
17.2	Information to be provided		
	<p>The information provided with the electrical equipment shall include:</p> <p>a) A main document (parts list or list of documents);</p> <p>b) Complementary documents</p>	P	
17.3	Requirements applicable to all documentation		
	<p>Unless otherwise agreed between manufacturer and user:</p> <ul style="list-style-type: none"> – the documentation shall be in accordance with relevant parts of IEC 61082; – reference designations shall be in accordance with relevant parts of IEC 61346; – instructions/manuals shall be in accordance with IEC 62079. – parts lists where provided shall be in accordance with IEC 62027, class B. <p>NOTE See item 13 of Annex B.</p> <p>For referencing of the different documents, the supplier shall select one of the following methods:</p> <ul style="list-style-type: none"> – where the documentation consists of a small number of documents (for example less than 5) each of the documents shall carry as a cross-reference the document numbers of all other documents belonging to the electrical equipment; or – for single level main documents only (see IEC 62023), all documents shall be listed with document numbers and titles in a drawing or document list; or – all documents of a certain level (see IEC 62023) of the document structure shall be listed, with document numbers and titles, in a parts list belonging to the same level. 	P	
17.4	Installation documents		
	<p>The installation documents shall give all information necessary for the preliminary work of setting up the machine (including commissioning). In complex cases, it may be necessary to refer to the assembly drawings for details.</p>	P	
17.5	Overview diagrams and function diagrams		
	<p>Where it is necessary to facilitate the understanding of the principles of operation, an overview diagram shall be provided. An overview diagram symbolically represents the electrical equipment together with its functional interrelationships without necessarily showing all of the interconnections.</p> <p>NOTE 1 Examples of overview diagrams can be found in IEC 61082 series.</p> <p>Function diagrams may be provided as either part of, or in addition to, the overview diagram.</p> <p>NOTE 2 Examples of function diagrams can be found in IEC 61082-2.</p>	P	
17.6	Circuit diagrams		
	<p>A circuit diagram(s) shall be provided. This diagram(s) shall show the electrical circuits on the machine and its associated electrical equipment. Any graphical symbol not shown in IEC 60617-DB: 2001 shall be separately shown and described on the diagrams or supporting documents. The symbols and identification of components and devices shall be consistent throughout all documents and on the machine.</p> <p>Where appropriate, a diagram showing the terminals for interface connections shall be provided. That diagram may be used in conjunction with the circuit diagram(s) for simplification. The diagram should contain a reference to the detailed circuit diagram of each unit shown.</p> <p>Switch symbols shall be shown on the electromechanical diagrams with all supplies turned off (for example electricity, air, water, lubricant) and with the machine and its electrical equipment ready for a normal start.</p> <p>Conductors shall be identified in accordance with 13.2.</p>	P	

Clause	Requirement-Test	Result	Verdict
--------	------------------	--------	---------

	Circuits shall be shown in such a way as to facilitate the understanding of their function as well as maintenance and fault location. Characteristics relating to the function of the control devices and components which are not evident from their symbolic representation shall be included on the diagrams adjacent to the symbol or referenced to a footnote.		
17.7	Operating manual		
	The technical documentation shall contain an operating manual detailing proper procedure for set-up and use of the electrical equipment. Particular attention should be given to the safety measures provided. Where the operation of the equipment can be programmed, detailed information on methods of programming, equipment required, program verification, and additional safety procedures(where required) shall be provided.	P	Operating manual
17.8	Maintenance manual		
	The technical documentation shall contain a maintenance manual detailing proper procedures for adjustment, servicing and preventive inspection, and repair. Recommendations on Maintenance/service intervals and records should be part of that manual. Where methods for the verification of proper operation are provided (for example software testing programs), the use of those methods shall be detailed.	P	Maintenance manual
17.9	Parts list		
	The parts list, where provided, shall comprise, as a minimum, information necessary for ordering spare or replacement parts (for example components, devices, software, test equipment, technical documentation) required for preventive or corrective maintenance including those that are recommended to be carried in stock by the user of the equipment.	P	

18 Verification

18.2	TABLE: Earth bonding		P
	Test Current (A)..... :	10A	—
	Ambient (°C)..... :	25	—
Test locations		Conductor Diameter (mm ²)	Voltage Drop (V)
Most unfavorable case	PE- enclosure		0.77
	PE- transformer		0.66
	PE- motor		0.99
	PE- other parts		0.99
18.2	TABLE: Fault loop impedance		P
	Ambient (°C)..... :	25	—
Most unfavorable case	U ₀ (V)	244	
	I _a (A)	30	
	Z _s Ω	0.95	
18.3	TABLE: Insulation Resistance Test		P
	Test Voltage (V)..... :	1000V a.c.	—
	Ambient (°C)..... :	20	—
Test locations		Insulation Resistance (MΩ)	
Most unfavorable case	PE-L1	100	
	PE-L2	100	

Clause	Requirement-Test	Result	Verdict
	PE-L3	100	
	PE-N	100	
18.4	TABLE: Dielectric Test		P
	Test Voltage (V)..... :	1000V a.c.	—
	Test Duration (s)..... :	1 sec.	—
Test locations		Observation	
Most unfavorable case	L1-PE	<input type="checkbox"/> Puncture <input type="checkbox"/> Flash-over	
	L2-PE	<input type="checkbox"/> Puncture <input type="checkbox"/> Flash-over	
	L2-PE	<input type="checkbox"/> Puncture <input type="checkbox"/> Flash-over	
	N-PE	<input type="checkbox"/> Puncture <input type="checkbox"/> Flash-over	
CMS-16SW	L1-PE	<input type="checkbox"/> Puncture <input type="checkbox"/> Flash-over	
	L2-PE	<input type="checkbox"/> Puncture <input type="checkbox"/> Flash-over	
	L2-PE	<input type="checkbox"/> Puncture <input type="checkbox"/> Flash-over	
	N-PE	<input type="checkbox"/> Puncture <input type="checkbox"/> Flash-over	
18.5	Protection against residual voltages		
	Where appropriate, tests shall be performed to ensure compliance with 6.2.4.	P	Test Voltage (V) 220AC
18.6	Functional tests		
	The functions of electrical equipment shall be tested. The function of circuits for electrical safety (for example earth fault detection) shall be tested.	P	

Photos of the sample



Picture 1



Picture 2

ANNEX

CE certificates for Electric components